

Anertec & Gandy Company
Agriculture Row Crop Applicator
and Drop Spreader Price Book
January 1, 2015



815 Rice Lake Street, Owatonna, MN 55060-0528 USA
Telephone: 507-451-5430 800-443-2476 USA/800-597-4263 Canada Fax: 507-451-2857
Web site: www.gandy.net Email: custsrv@gandy.net

TABLE OF CONTENTS

2015 Row Crop Applicator and Drop Spreader Price Book



Poly Multi-Purpose Row Applicators.....	1 - 6
<i>100 lb. Capacity Multi-Purpose Row Applicator.....</i>	<i>1 - 3</i>
<i>45 lb. Capacity Multi-Purpose Row Applicator.....</i>	<i>4 - 6</i>
Row Applicator Reference Pages.....	13 - 17
<i>Individual Items for Row Applicators.....</i>	<i>13</i>
<i>Electric, Hydraulic and Ground Drives.....</i>	<i>14</i>
<i>Accessories.....</i>	<i>15</i>
<i>Rotor Bar Packages, Bottom/Slides.....</i>	<i>16</i>
<i>Dimensions and Diagrams.....</i>	<i>17</i>
Forage Preservative Applicators.....	18 - 21
<i>100 lb. Capacity Poly Forage Preservative Cam Gauge Applicator.....</i>	<i>18 - 19</i>
<i>45 lb. Capacity Poly Forage Preservative Cam Gauge Applicators.....</i>	<i>20 - 21</i>
Poly Hopper Humus, Inoculant and Talc Applicators.....	22 - 23
65-Series Turf Drop Spreaders.....	24 - 33
65-Series Tractor Hitch	
<i>4-, 5- and 6-ft. Turf Spreader with Tractor Hitch</i>	<i>24 - 26</i>
65-Series 3-Pt Hitch End-Wheel Drive	
<i>5- and 6-ft. Turf Spreader with 3-Pt. Hitch, End-Wheel Drive</i>	<i>27 - 29</i>
Con't. on next page	

TABLE OF CONTENTS CON'T.

2015 Row Crop Applicator and Drop Spreader Price Book



65-Series Turf Drop Spreaders Con't.....	24 - 33
65-Series 3-Pt Hitch	
<i>4-, 5- and 6-ft. Turf Spreader with 3-Pt. Hitch.....</i>	<i>30 - 31</i>
65-Series Adjustable Slotted Bottom	
<i>4 and 6-ft. Adjustable Slotted Bottom Spreaders.....</i>	<i>32 - 33</i>
10T-Heavy-Duty Drop Spreaders.....	34 - 45
10T Series with Tractor Hitch	
<i>6-, 8-, 10- & 12-ft. Spreaders with Tractor Hitch.....</i>	<i>34 - 36</i>
10TR Series with 3-Pt. Hitch and End-Wheel Drive	
<i>6-, 8-, 10- & 12-ft. Spreaders with 3-Pt. Hitch and End-Wheel Drive.....</i>	<i>37 - 39</i>
10T-PTH Series with 3-Pt. Hitch	
<i>6-, 8-, 10- & 12-ft. Spreaders with 3-Pt. Hitch.....</i>	<i>40 - 42</i>
10T-TBM Series for Mounting to Parent Implement	
<i>6-, 8-, 10- & 12-ft. Spreaders for Implement Mount....</i>	<i>43 - 45</i>
Linear Applicator with Tool Bar for Grass Seed and Granular Chemicals.....	46 - 47
Land Measuring Wheels.....	48

100-LB. CAPACITY MULTI-PURPOSE APPLICATOR



Fertilize, Seed or Apply Granular Chemicals with Just One Applicator. Comes with Three Sets of Full-Rate Metering Wheels

Standard Equipment

- 2.3 cu. ft. (140 lb. capacity for fertilizer at 60 lb. per cu. ft. density / 100 lbs. capacity for seed and chemical) polyethylene hopper with stainless steel housing to resist corrosion. Includes U-frame mount with 1/2" pre-drilled holes and slots for mounting.
- Includes four full-rate black metering wheels for small seeds like alfalfa, canola and granular chemicals; four red metering wheels for small grains such as oats, wheat, rice, barley and fertilizer; four yellow hi-output fertilizer metering wheels. Operator can install from one to four outlets on a single applicator depending upon field requirements. **Note:** For chemical and fertilizer applications requiring less than 4 lbs./acre, customer will need to order half-rate metering wheels.
- Product is fed under the metering wheel to dispense particles down the tube. Positive shutoff when metering stops
- Speed compensated rate if ground driven
- Non-speed compensated electric drive available
- Factory rate charts are based on a drive input to the hopper shaft of 2 or 4 revolutions in 88 feet provided by Gandy ground drive or a user-made sprocket and chain drive from a parent implement shaft.
- Sprocket cluster package, ordered separately, sets the rates and can control several hoppers set up in line through use of connector tubes.
- Requires 1.5" I.D. tubing with hose clamps to secure tubing to outlet. 7/8" tubing with hose clamps are required when spout adapters are used. Order separately as needed.
- Some assembly required.

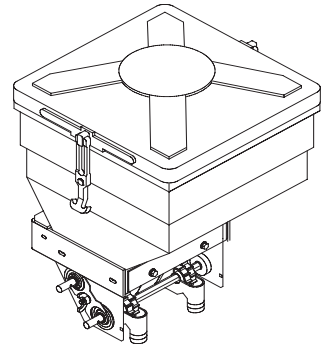

SPECIFICATIONS: Neutral polyethylene hopper, heat reflective silver lid with strap latches, positive displacement applicator assembly, Includes red (F) fertilizer, black (C) chemical and yellow (V) hi-output fertilizer metering wheels with open stainless steel housing and see-through weather-guard shield. U-frame bracket with 1/2-inch holes and slots for mounting is included. Internal agitator standard.

EXTRA EQUIPMENT: Rate control sprocket package, drop tubing, hose clamps are ordered separately. Purchaser will have to provide chain and drive sprocket to hopper input shaft from the parent implement's live shaft to provide 2 or 4 rpm in 88-ft. of ground travel to the Gandy input shaft depending on chemical rate, or purchase the Gandy ground drive package.

OPTIONS: Agitator that secures to internal drive shaft is standard equipment; however, if multiple hoppers are mounted in line, connector tubes will be needed to connect each hopper's drive and agitator shafts. Number of in-line hoppers possible will depend on torque created by product being applied.

Con't. on next page

POLY-STAINLESS MP⁺³ MULTI-PURPOSE APPLICATOR



Ground, Hydraulic and Electric-Motor Driven Applicator for Planters, Cultivators, Nurseries, etc.

1 SELECT APPLICATOR

Order No.	Description	Shp Wgt	List Price
09PDMS	Multi-purpose poly stainless applicator with four each black metering wheels for small seeds and granular chemicals; red metering wheels for small grains and fertilizer; yellow hi-output fertilizer metering wheels. Includes four spout adapters for use with granular chemical. Includes U-frame mounting bracket with 1/2" pre-drilled holes and slots for mounting. Operator can configure applicator from one to four outlets. Blank plates included to independently block off unused outlets.	39 lbs.	\$ 813.00
09PDMSLL	Same as above, but, with Lock 'n Load lid and valve	40 lbs.	\$ 916.00

2 CHOOSE A GROUND OR ELECTRIC DRIVE PACKAGE BELOW

SPEED-COMPENSATED GROUND DRIVE PACKAGE

Order No.	Description	Shp Wgt	List Price
09094903	Speed-compensated ground drive package with 480/400x8, 4-ply tire. Attaches to diamond or flat tool bar, includes drive sprockets and chain.	85 lbs.	\$ 808.00

OR

NON-SPEED COMPENSATED ELECTRIC MOTOR DRIVE PACKAGES

Order No.	Description	Shp Wgt	List Price
09099934	12-volt, 4 amp, 1/64 hp electric motor with on/ff switch, drive sprockets, chain and guard. Drives up to two hoppers.		\$ 314.00
09004956	12-volt, 25 amp, 1/4 hp heavy-duty electric motor complete with on/off switch, drive sprockets, chain and guard. Drives up to eight hoppers.		\$ 1,148.00

3 RATE CONTROL SPROCKET PACKAGE FOR 12V, 110V OR HYDRAULIC DRIVE

Order No.	Description	Shp Wgt	List Price
09099930	Set of 12 sprockets to regulate application rates when an electric or ground drive is chosen. Includes sprockets, stub connector, chain and guard.	6 lbs.	\$ 193.00

One sprocket package is required for each hopper. Unless multiple hoppers are mounted in-line with shaft connector. Then, only one (1) rate control sprocket package is required.

Con't. on next page

POLY-STAINLESS MP⁺³ MULTI-PURPOSE APPLICATOR



Ground, Hydraulic and Electric-Motor Driven Applicator for Planters, Cultivators, Nurseries, etc.

4 SELECT TUBING

Order No.	Description	Shp Wgt	List Price
M06-1500-010	1.5" I.D. clear flexible tubing. Order in foot lengths.		\$3.00/ft.
M11-0024-000	Hose clamp, 1-2".		\$ 2.00
M06-0875-000	7/8-inch I.D. clear flexible tubing. Order in foot length. For use with hopper when seeding or applying low rates of granular chemicals and require smaller tube for opener placement. Note: this tubing is used with spout adapter, no. 09094899-9 for granular chemical applications.		\$4.00/ft.
M11-0012-010	Hose clamp, 5/8 to 1-1/4". For use with 7/8" I.D. tubing		\$ 2.00

5 OPTIONAL CONNECTOR PACKAGES WHEN MOUNTING MULTIPLE HOPPERS IN-LINE

Order No.	Description	Shp Wgt	List Price
09074321	Connector drive tube, use to connect metering shaft or drive shaft in line, up to 42-inch spacing. Note: If agitators are used, separate connector drive tubes will be needed to connect the drive shafts and agitator shafts.	3 lbs.	\$ 70.00
09074323	Connector drive tube, use to connect metering shaft or drive shaft in line, up to 80-inch spacing. Note: If agitators are used, separate connector drive tubes will be needed to connect the drive shafts and agitator shafts.	4 lbs.	\$ 81.00

6 FIELD INSTALLED OPTIONS AND WEAR PARTS

Order No.	Description	Shp Wgt	List Price
09099931	Agitator replacement package, 2-piece.		\$ 29.00
628751-75	Black chemical metering wheel with cavity inserts	4 oz.	\$ 17.00
M10-0001-040	Red (F) fertilizer wheel.	4 oz.	\$ 9.00
M10-0001-055	Yellow (V) hi-output fertilizer metering wheel to increase fertilizer rate approximately 1.6 times that of red metering wheel. Note: this wheel may meter more product volume than the system can deliver.	4 oz.	\$ 9.00
M10-0001-100	Metering cup	4 oz.	\$ 8.00
09096921	Half-rate black chemical wheel and spacer package	1 lb.	\$ 37.00
09096921R	Half-rate red fertilizer wheel and spacer package.	1 lb.	\$ 51.00
09099946	Latch package for poly hopper lid (replacement).		\$ 39.00
M05-0000-008	Rubber replacement latch only, 4".		\$ 18.00
09094899-9	Insert adaptor for metering cup to accept 7/8" I.D. tubing.		\$ 6.00
C08-0138-030	#6-32 sheet metal screw.		\$ 1.00

P45 MULTI-PURPOSE APPLICATOR



Fertilize, Seed or Apply Granular Chemicals with Just One Applicator.
Comes with Three Sets of Full-Rate Metering Wheels

Standard Equipment

- 45 lb. poly hopper with stainless steel housing to resist corrosion. Includes U-frame with 1/2" pre-drilled holes and slots for surface mounting.
- Includes four full-rate black metering wheels for small seeds like alfalfa, canola and granular chemicals; four red metering wheels for small grains such as oats, wheat, rice, barley and fertilizer; four yellow hi-output fertilizer metering wheels. Operator can install from one to four outlets on a single applicator depending upon field requirements. **Note:** For chemical and fertilizer applications requiring less than 4 lbs./acre, customer will need to order half-rate metering wheels.
- Product is fed under the metering wheel to dispense particles down the tube. Positive shutoff when metering stops
- Speed compensated rate if ground driven
- Non-speed compensated electric drive available
- Factory rate charts are based on a drive input to the hopper shaft of 2 or 4 revolutions in 88 feet provided by Gandy ground drive or a user-made sprocket and chain drive from a parent implement shaft.
- Sprocket cluster package, ordered separately, sets the rates and can control several hoppers set up in line through use of connector tubes.
- Requires 1.5" I.D. tubing with hose clamps to secure tubing to outlet. 7/8" tubing with hose clamps are required when spout adapters are used. Order separately as needed.
- Some assembly required.



SPECIFICATIONS: Neutral polyethylene hopper and lid with strap latches, positive displacement applicator assembly, Includes red (F) fertilizer, black (C) chemical and yellow (V) hi-output fertilizer metering wheels with open stainless steel housing and see-through weather-guard shield. U-frame bracket with 1/2-inch holes and slots for mounting is included. Internal agitator standard.

EXTRA EQUIPMENT: Rate control sprocket package, drop tubing, hose clamps are ordered separately. Purchaser will have to provide chain and drive sprocket to hopper input shaft from the parent implement's live shaft to provide 2 or 4 rpm in 88-ft. of ground travel to the input shaft depending on chemical rate or purchase a ground

OPTIONS: Agitator that secures to internal drive shaft is standard equipment; however, if multiple hoppers are mounted in line, connector tubes will be needed to connect each hopper's drive and agitator shafts. Number of in-line hoppers possible will depend on torque created by product being applied.

Con't. on next page

P45 MULTI-PURPOSE APPLICATOR



Ground, Hydraulic and Electric-Motor Driven Applicator for Planters, Cultivators, Nurseries, etc.

1 SELECT APPLICATOR

Order No.	Description	Shp Wgt	List Price
P45PDMS	Multi-purpose 45-lb. capacity poly stainless applicator with four each black metering wheels for small seeds and granular chemicals; red metering wheels for small grains and fertilizer; yellow hi-output fertilizer metering wheels. Includes four spout adapters for use with granular chemical. Includes U-frame mounting bracket with 1/2" pre-drilled holes and slots for mounting. Operator can configure applicator from one to four outlets. Blank plates included to independently block off unused outlets.	39 lbs.	\$ 651.00
P45PDMSLL	Same as above with Lock 'N Load® cover and valve	40 lbs.	\$ 720.00

2 CHOOSE A GROUND OR ELECTRIC DRIVE PACKAGE BELOW

SPEED-COMPENSATED GROUND DRIVE PACKAGE

Order No.	Description	Shp Wgt	List Price
09094903	Speed-compensated ground drive package with 480/400x8, 4-ply tire. Attaches to diamond or flat tool bar, includes drive sprockets and chain.	85 lbs.	\$ 808.00

OR

NON-SPEED COMPENSATED ELECTRIC MOTOR DRIVE PACKAGES

Order No.	Description	Shp Wgt	List Price
09099934	12-volt, 4 amp, 1/64 hp electric motor with on/ff switch, drive sprockets, chain and guard. Drives up to two hoppers.		\$ 314.00
09004956	12-volt, 25 amp, 1/4 hp heavy-duty electric motor complete with on/off switch, drive sprockets, chain and guard. Drives up to eight hoppers.		\$ 1,148.00

3 RATE CONTROL SPROCKET PACKAGE FOR 12V, 110V OR HYDRAULIC DRIVE

Order No.	Description	Shp Wgt	List Price
09099930	Set of 12 sprockets to regulate application rates when an electric or ground drive is chosen. Includes sprockets, stub connector, chain and guard.	6 lbs.	\$ 193.00

One sprocket package is required for each hopper. Unless multiple hoppers are mounted in-line with shaft connector. Then, only one (1) rate control sprocket package is required.

Con't. on next page

P45 MULTI-PURPOSE APPLICATOR



Ground, Hydraulic and Electric-Motor Driven Applicator for Planters, Cultivators, Nurseries, etc.

4 SELECT TUBING

Order No.	Description	Shp Wgt	List Price
M06-1500-010	1.5" I.D. clear flexible tubing. Order in foot lengths.		\$3.00/ft.
M11-0024-000	Hose clamp, 1-2".		\$ 2.00
M06-0875-000	7/8-inch I.D. clear flexible tubing. Order in foot length. For use with hopper when seeding or applying low rates of granular chemicals and require smaller tube for opener placement. Note: this tubing is used with spout adapter, no.		\$4.00/ft.
M11-0012-010	Hose clamp, 5/8 to 1-1/4". For use with 7/8" I.D. tubing		\$ 2.00

5 OPTIONAL CONNECTOR PACKAGES WHEN MOUNTING MULTIPLE HOPPERS IN-LINE

Order No.	Description	Shp Wgt	List Price
09074321	Connector drive tube, use to connect metering shaft or drive shaft in line, up to 42-inch spacing. Note: If agitators are used, separate connector drive tubes will be needed to connect the drive	3 lbs.	\$ 70.00
09074323	Connector drive tube, use to connect metering shaft or drive shaft in line, up to 80-inch spacing. Note: If agitators are used, separate connector drive tubes will be needed to connect the drive	4 lbs.	\$ 81.00

6 FIELD INSTALLED OPTIONS AND WEAR PARTS

Order No.	Description	Shp Wgt	List Price
P45-EXT	32-lb. capacity extension package with mounting hardware and silicone sealant		\$ 155.00
09099931	Agitator replacement package, 2-piece.		\$ 29.00
628751-75	Black chemical metering wheel with cavity inserts	4 oz.	\$ 17.00
M10-0001-040	Red (F) fertilizer wheel.	4 oz.	\$ 9.00
M10-0001-055	Yellow (V) hi-output fertilizer metering wheel to increase fertilizer rate approximately 1.6 times that of red metering wheel. Note: this wheel may meter more product volume than the system can deliver.	4 oz.	\$ 9.00
M10-0001-100	Metering cup	4 oz.	\$ 8.00
09096921	Half-rate black chemical wheel and spacer package	1 lb.	\$ 37.00
09096921R	Half-rate red fertilizer wheel and spacer package.	1 lb.	\$ 51.00
09099946	Latch package for poly hopper lid (replacement).		\$ 39.00
M05-0000-008	Rubber replacement latch only, 4".		\$ 18.00
09094899-9	Insert adaptor for metering cup to accept 7/8" I.D. tubing.		\$ 6.00
C08-0138-030	#6-32 sheet metal screw.		\$ 1.00

100- LB. POLY CAM-GAUGE ROW APPLICATORS



Cam Gauge Metering of Insecticides and Herbicides

- 2.3 cu. ft. capacity poly hoppers (approximate 100 lb. capacity)
- Optional Lock 'n Load lid available
- U-frame bracket included with 1/2" pre-drilled holes and slots for mounting
- 2, 3 or 4 openings

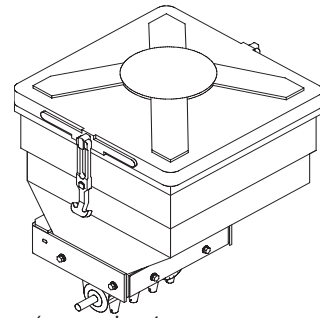

SPECIFICATIONS: 100-pound (45 kg) capacity low density polyethylene hopper (approximate, with clay ag chemical granules at 45 lb. per cu. ft.), with bolt-on stainless steel hopper bottom and slide; bolt-on mounting for easy removal; precision cam-type rate gauge; five-bladed Flo-Control rotor; sealed bearings. Color, natural, with silver lid and latch straps. NOTE: This bottom and slide is not interchangeable with the snap-on bottom and slide used with steel hoppers. U-frame mounting bracket with 1/2" holes and slots included.

® Lock 'n Load is a registered trademark of BASF Company and Deere and Company

Poly Hopper Cam Gauge

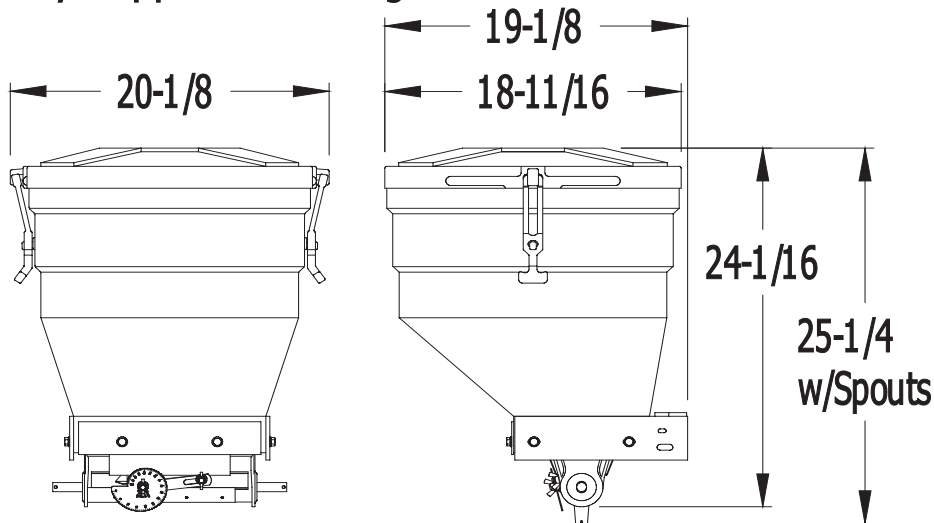

Con't. on next page

100- LB. POLY CAM-GAUGE ROW APPLICATORS - CON'T.



Cam Gauge Metering of Insecticides and Herbicides

1 SELECT A 100 LB. CAPACITY POLY CAM-GAUGE APPLICATOR PACKAGE

Order No.	Description	Shp Wgt	List Price
09PC02-R	100-lb. row crop applicator package consisting of hopper with two openings, twin rubber rotor bar, "U" frame mounting bracket, two 42-inch flexible tubes, hose clamps, stabilizers, and clamp straps.	45 lbs.	\$ 607.00
09PC02-RLL	Same as above with Lock 'n Load cutout and valve	46 lbs.	\$ 710.00
09PC03-R	100-lb. row crop applicator package consisting of hopper with two openings, rubber rotor bar, "U" frame mounting bracket, two 42-inch flexible tubes, hose clamps, stabilizers, and clamp straps.	46 lbs.	\$ 624.00
09PC03-RLL	Same as above with Lock 'n Load cutout and valve	47 lbs.	\$ 727.00
09PC04-R	100-lb. row crop applicator package consisting of hopper with two openings, rubber rotor bar, "U" frame mounting bracket, two 42-inch flexible tubes, hose clamps, stabilizers, and clamp straps.	47 lbs.	\$ 634.00
09PC04-RLL	Same as above with Lock 'n Load cutout and valve	48 lbs.	\$ 737.00

2 OPTIONAL GROUND, ELECTRIC OR HYDRAULIC DRIVE PACKAGES

You must select a drive package for your hopper. Choices are ground, electric or hydraulic drive. If you are mounting multiple hoppers in-line, select appropriate drive for operating multiple hoppers.

OPTIONAL GROUND DRIVE PACKAGE

Order No.	Description	Shp Wgt	List Price
09069286R-C1	Ground-drive, non-speed compensating with rubber wheel. Attaches to diamond or flat tool bar. Comes with driven sprocket and chain.	53 lbs.	\$ 809.00

OPTIONAL 12-VOLT ELECTRIC DRIVE PACKAGES

Order No.	Description	Shp Wgt	List Price
09099928	12-volt, 1/64 hp motor with mounting, motor, chain, guard. May drive up to 2 hoppers.		\$ 325.00
09099929	12-volt, 1/32 hp motor with mounting, motor, chain, guard. May drive up to 3 hoppers.		\$ 465.00

OPTIONAL HYDRAULIC DRIVE

Order No.	Description	Shp Wgt	List Price
09099941	*Hydraulic drive for poly cam-gauge hopper with mounting, motor, chain guard. Drives multiple hoppers when applicators are mounted in-line.		\$ 1,009.00

Con't. on next page

100- LB. POLY CAM-GAUGE ROW APPLICATORS - CON'T.



3 OPTIONAL CONNECTOR PACKAGES WHEN MOUNTING MULTIPLE HOPPERS IN-LINE

Order No.	Description	Shp Wgt	List Price
09074321	Connector drive tube for hoppers spaced up to 42" apart	3 lbs.	\$ 70.00
09074323	Connector drive tube for hoppers spaced up to 80" apart	3 lbs.	\$ 81.00

4 OPTIONAL TUBING AND RO-BANDERS (RO-BANDER ILLUSTRATIONS SEE PAGE 37)

Order No.	Description	Shp Wgt	List Price
M06-0875-000	.875-inch ID clear flexible tubing. Order by the foot.		\$4.00/ft.
2406224-36	.810-inch ID clear tubing - 36" length (available in lengths up to 108").		\$ 11.00
M11-0012-010	Mini-hose clamp, 5/8" x 1-1/4". (secures tube to spout).		\$ 2.00
09105D	5" ro-bander.	2 lbs.	\$ 31.00
09107D	7" ro-bander.	2 lbs.	\$ 29.00
09110D	10" ro-bander.	2 lbs.	\$ 36.00
09114	14" ro-bander (comes with mounting brackets).	2 lbs.	\$ 67.00
09073673	Attaching bracket for single ro-bander to tool bar.	2 lbs.	\$ 59.00

5 FIELD INSTALLED MOUNTING OPTIONS (ILLUSTRATIONS SHOWN ON PAGE 35)

Order No.	Description	Shp Wgt	List Price
09073649EMS	Adjustable tool bar mount (14" to 24") fits up to 5" diamond or 7" square tool bar.	14 lbs.	\$ 137.00

P45 POLY CAM-GAUGE ROW APPLICATORS



Cam Gauge Metering of Insecticides and Herbicides

- 45-lb., capacity poly hopper
- Optional Lock 'n Load® lid packages available
- U-frame bracket included with 1/2" pre-drilled holes and slots for mounting
- 1, 2, 3 or 4 openings
- Optional 12-volt electric drive or ground drive package



SPECIFICATIONS: 45-pound capacity low density polyethylene hopper (approximate, with clay ag chemical granules at 45 lb. per cu. ft.), with bolt-on stainless steel hopper bottom and slide; bolt-on mounting for easy removal; precision cam-type rate gauge; five-bladed Flo-Control rotor; sealed bearings. Hopper color, natural, with matching lid and latch straps. NOTE: This bottom and slide is not interchangeable with the snap-on bottom and slide used with steel hoppers. U-frame mounting bracket with 1/2" holes and slots included.

Lock 'n Load® is a registered trademark of BASF Company and Deere and Company

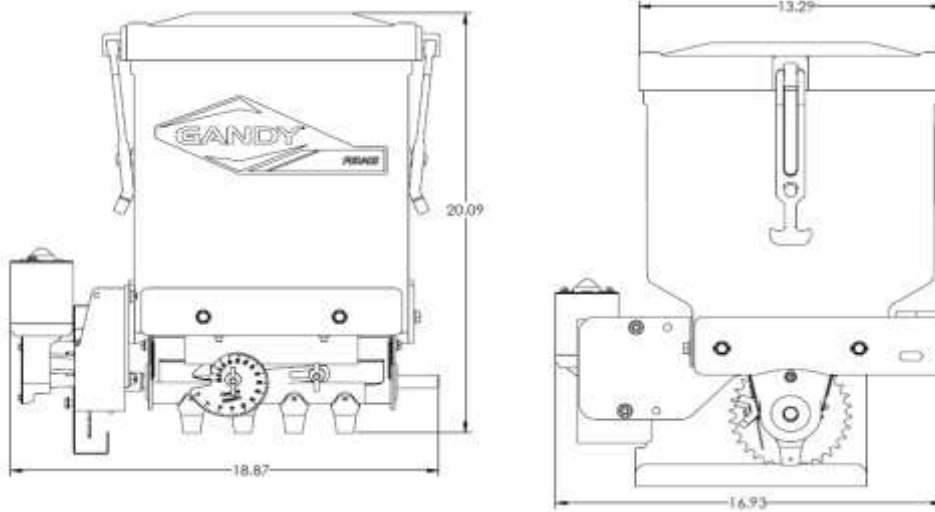

Shown with optional 12-volt electric motor

Con't. on next page

P45 POLY CAM-GAUGE ROW APPLICATORS - CON'T.



Cam Gauge Metering of Insecticides and Herbicides

1 SELECT A 45 LB. CAPACITY POLY CAM-GAUGE APPLICATOR PACKAGE

Order No.	Description	Shp Wgt	List Price
P451-R	45-lb. row crop applicator package consisting of hopper with one opening stainless steel bottom and slide, rubber rotor bar and "U" frame bracket for surface mounting.		\$ 476.00
P451-RLL	Same as above with Lock 'n Load® cover and valve		\$ 508.00
P452-R	45-lb. row crop applicator package consisting of hopper with a two opening stainless steel bottom and slide, rubber rotor bar and "U" frame bracket for surface mounting.		\$ 479.00
P452-RLL	Same as above with Lock 'n Load® cover and valve		\$ 511.00
P453-R	45-lb. row crop applicator package consisting of hopper with a three opening stainless steel bottom and slide, rubber rotor bar and "U" frame bracket for surface mounting.		\$ 485.00
P453-RLL	Same as above with Lock 'n Load® cover and valve		\$ 517.00
P454-R	45-lb. row crop applicator package consisting of hopper with a four opening stainless steel bottom and slide, rubber rotor bar and "U" frame bracket for surface mounting.		\$ 490.00
P454-RLL	Same as above with Lock 'n Load® cover and valve		\$ 522.00

2 OPTIONAL GROUND OR ELECTRIC DRIVE PACKAGES

You must select a drive package for your hopper. Choices are ground or electric drive. If you are mounting multiple hoppers in-line, select appropriate drive for operating multiple hoppers.

OPTIONAL GROUND DRIVE PACKAGE

Order No.	Description	Shp Wgt	List Price
09069286-C1	Ground-drive, non-speed compensating with steel wheel. Attaches to diamond or flat tool bar. Comes with driven sprocket and chain.	69 lbs.	\$ 815.00
09069286R-C1	Ground-drive, non-speed compensating with rubber wheel. Attaches to diamond or flat tool bar. Comes with driven sprocket and chain.	53 lbs.	\$ 809.00

P45 POLY CAM-GAUGE ROW APPLICATORS - CON'T.



OPTIONAL 12-VOLT ELECTRIC DRIVE PACKAGES

Order No.	Description	Shp Wgt	List Price
09099928	12-volt, 1/64 hp motor with mounting, motor, chain, guard. May drive up to 2 hoppers.		\$ 325.00
09099929	12-volt, 1/32 hp motor with mounting, motor, chain, guard. May drive up to 3 hoppers.		\$ 465.00

3 OPTIONAL EM PACKAGE - TUBING, HOSE CLAMPS AND STRAPS (MUST ORDER 1 PACKAGE FOR EACH OUTLET ON P45 APPLICATOR)

Order No.	Description	Shp Wgt	List Price
09EM	Includes 42" flex tube, stabilizer strap and position strap. Order 1 package per outlet.		\$ 73.00

4 OPTIONAL CONNECTOR PACKAGES WHEN MOUNTING MULTIPLE HOPPERS IN-LINE

Order No.	Description	Shp Wgt	List Price
09074321	Connector drive tube for hoppers spaced up to 42" apart	3 lbs.	\$ 70.00
09074323	Connector drive tube for hoppers spaced up to 80" apart	3 lbs.	\$ 81.00

5 OPTIONAL TUBING AND RO-BANDERS® (RO-BANDER ILLUSTRATIONS SEE PAGE 37)

Order No.	Description	Shp Wgt	List Price
M06-0875-000	.875-inch ID clear flexible tubing. Order by the foot.		\$4.00/ft.
2406224-36	.810-inch ID clear tubing - 36" length (available in lengths up to 108").		\$ 11.00
M11-0012-010	Mini-hose clamp, 5/8" x 1-1/4". (secures tube to spout).		\$ 2.00
09105D	5" Ro-bander®.	2 lbs.	\$ 31.00
09107D	7" Ro-bander®.	2 lbs.	\$ 29.00
09110D	10" Ro-bander®.	2 lbs.	\$ 36.00
09114	14" Ro-bander® (comes with mounting brackets).	2 lbs.	\$ 67.00
09073673	Attaching bracket for single Ro-bander® to tool bar.	2 lbs.	\$ 59.00

6 FIELD INSTALLED MOUNTING OPTIONS (ILLUSTRATIONS SHOWN ON PAGE 35)

Order No.	Description	Shp Wgt	List Price
P45-EXT	30-lb. capacity extension package with mounting hardware and silicone sealant		\$ 155.00
09073649EMS	Adjustable tool bar mount (14" to 24") fits up to 5" diamond or 7" square tool bar.	14 lbs.	\$ 137.00

INDIVIDUAL ITEMS FOR ROW APPLICATORS

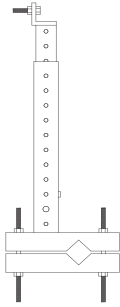
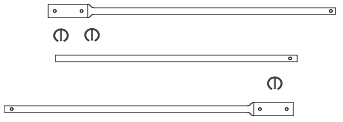
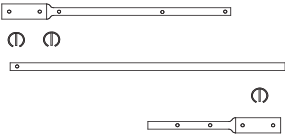
<p>09073649EMS \$137.00</p> <p>TOOL BAR MOUNTING</p> <p>adjustable 14-inches to 24-inches high. Fits up to 5-inch diamond or 7-inch square tool bar.</p> <p>WT. 14 lbs.</p>	 <p>A vertical assembly consisting of a long, narrow rectangular bar with a series of small circles along its length. At the top, there is a small horizontal bracket. At the bottom, the bar is mounted on a diamond-shaped base with two vertical support posts extending downwards.</p>	<p>09074323 \$81.00</p> <p>CONNECTOR DRIVE TUBE</p> <p>Use for up to 80-inch hopper spacing.</p> <p>WT. 3 lbs.</p>	 <p>Three horizontal tubes of varying lengths. The top tube has a small protrusion on its left end. The middle tube has two circular symbols (⊕) positioned above it. The bottom tube has a small protrusion on its right end.</p>
<p>09074321 \$70.00</p> <p>CONNECTOR DRIVE TUBE</p> <p>use for up to 42-inch hopper spacing.</p> <p>WT. 3 lbs.</p>	 <p>Three horizontal tubes of varying lengths. The top tube has a small protrusion on its left end. The middle tube has two circular symbols (⊕) positioned above it. The bottom tube has a small protrusion on its right end.</p>		

Drives for Row crop cam gauge applicators

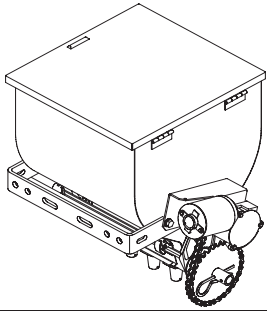
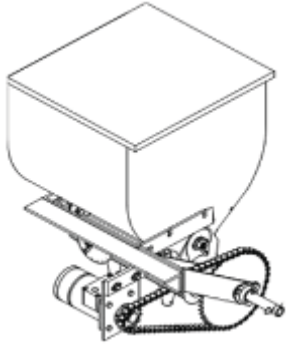
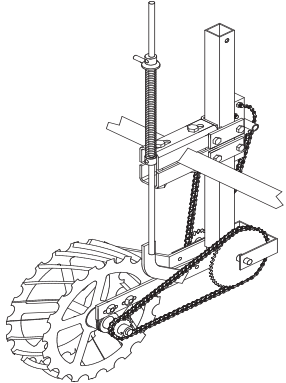
<p>09075589 \$ 259.00 12-VOLT ELECTRIC MOTOR DRIVE complete with switch, drive sprockets, chain and guard. 4 amp. 1/64 hp. Use on two hoppers. Silver or black color. WT. 11 lbs.</p>	
<p>*09075589-4SM \$ 211.00 12-VOLT SERVICE MOTOR with mount. WT. 5 lbs.</p>	
<p>*09075589-4 \$ 182.00 12-VOLT SERVICE MOTOR only. WT. 4 lbs.</p>	
<p>09082843 \$ 451.00 12-VOLT ELECTRIC MOTOR DRIVE complete with switch, sprockets, chain and guard. 6 amp, 1/32 hp for use with up to three hoppers. <i>Not for use on PDM or PDA applicators.</i> WT. 13 lbs.</p>	
<p>09082842-4 \$ 314.00 12-VOLT SERVICE MOTOR only with drive sprocket. WT. 6 lbs.</p>	
<p>09093895 \$ 1,193.00 HEAVY DUTY ELECTRIC MOTOR DRIVE complete with switch and drive parts. May be used in place of hydraulic. 25 amp, 1/4 hp for up to 12 hoppers. WT. 42 lbs.</p>	
<p>*L01-0012-007 \$ 565.00 HEAVY DUTY ELECTRIC MOTOR only. WT. 9 lbs.</p>	
<p>09074678 \$ 964.00 HYDRAULIC MOTOR DRIVE complete with Flo-Control valve, drive sprockets, chain and bracket. WT. 24 lbs.</p>	
<p>09076679-C1 \$ 718.00 HYDRAULIC C7K MOTOR with 09076691 Flo-Control. WT. 19 lbs.</p>	
<p>09069286R-C1 \$ 815.00 GROUND DRIVE, RUBBER TIRE Attaches to diamond or flat tool bar. Complete with driven sprocket and chain. Use with hopper mount 09073649EMS. WT. 69 lbs.</p>	

**These items receive parts pricing.*

ACCESSORIES

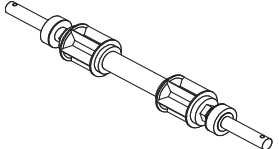
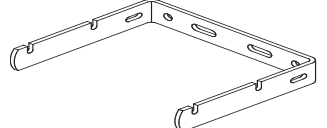
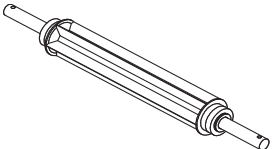
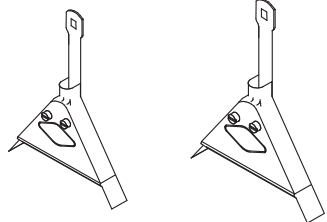
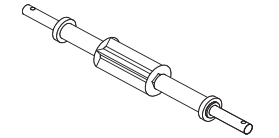
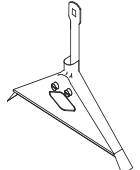
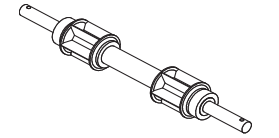
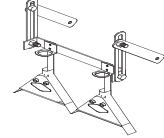
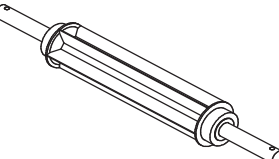
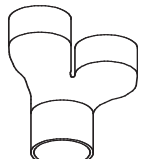
<p>*09076719-C1P \$90.00</p> <p>TWIN RESILIENT RUBBER ROTOR, for two-outlet Jumbo applicator. Use with heavy-core granules (16-3/4" shaft). Includes washers, O-rings and nylon bushings</p> <p>WT. 2 lb.</p>		<p>09072624-3 \$54.00 "U" FRAME for Super or Junior applicators</p> <p>09072654-3 \$54.00 "U" FRAME for Jumbo applicators WT. 4 lb.</p>	
<p>*09070534P \$82.00</p> <p>RESILIENT RUBBER ROTOR, 10-inch for Jumbo applicators. Use with heavy-core granules (16-3/4" shaft). Includes washers and O-rings.</p> <p>WT. 2 lb.</p>		<p>09105D \$31.00 5-INCH RO-BANDER.</p> <p>WT. 2 lbs.</p> <p>09107D \$29.00 7-INCH RO-BANDER WT. 2 lbs</p>	
<p>*09069507P \$85.00</p> <p>RESILIENT RUBBER ROTOR, 3-inch, for single outlet Super, Junior or Poly applicators. Use with heavy-core granules. Includes washers, spacers and O-rings.</p> <p>WT. 2 lb.</p>		<p>09110D \$36.00 10-INCH RO-BANDER</p> <p>WT. 2 lb.</p>	
<p>09076719P \$83.00</p> <p>TWIN RESILIENT RUBBER ROTOR for two-outlet Super, Junior or Poly applicators. Includes washers and O-rings.</p> <p>WT. 2 lb.</p>		<p>09114 \$67.00 14-INCH RO-BANDER complete with mounting brackets</p> <p>WT. 2 lb.</p>	
<p>*09069508P \$83.00</p> <p>RESILIENT RUBBER ROTOR, 8-inch, for Super, Junior or Poly applicators. Use with heavy-core granules. Includes washers and O-rings.</p> <p>WT. 2 lb.</p>		<p>M10-2539-200 \$47.00 WYE CONNECTOR for use on two outlets or to combine material from two hoppers to one tube. Ports are 1-1/4" I.D.</p> <p>WT. 1 lb.</p>	

JUNIOR, SUPER & POLY CAM APPLICATORS

JUMBO APPLICATORS

Rotor Bar Packages

Part No.	Description
09076719-C1P	Resilient rubber rotor, twin, as option for heavy-core granules
09070534P	Rubber rotor, 10", available as option for heavy-core granules
0917422P	Stainless steel rotor, 10"



Bottom and Slides







Part No.	Description
09173669-2	Btm/slide, angle toward gauge, 2 opening
09173669-2C1	Bottom & slide, straight spout, 2 opening
09173669-2C2	Bottom & slide, spout angled away from gauge, 2 openings
09173669-3	Btm/slide, angle toward gauge, 3 opening
09173669-3C1	Bottom & slide, straight spout, 3 opening
09173669-3C2	Bottom & slide, spout angled away from gauge, 3 openings
09173669-4	Btm/slide, angle toward gauge, 4 opening
09173669-4C1	Bottom & slide, straight spout, 4 opening
09173669-4C2	Bottom & slide, spout angled away from gauge, 4 opening

Tubing

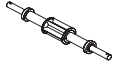
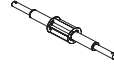
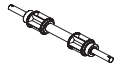
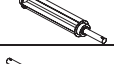
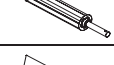
Part No.	Description
2406224-36	Plastic tube, clear, 36"
2407924-30	Plastic tube, rigid, 30" (Ordered in inch length)
M06-0875-000	Flex tubing, maximum 25 ft. roll

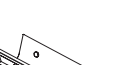
Options

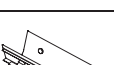
	0906375	Cam Gauge, Stainless
	09072638	Lock Strip
	0906747 0906949 9067242 0906646-3 0906949-3 09067243	7" Ro-Bander less cover 5" Ro-Bander less cover 10" Ro-Bander less cover 7" Ro-Bander cover only 5" Ro-Bander cover only 10" Ro-Bander cover only

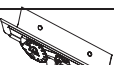
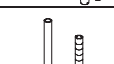
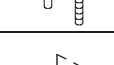
	09069507P	Resilient rubber rotor, 3" Available as option
	09074199P	Rotor, 3", 5 blades, stainless steel
	09076719P 09076719PC	Resilient rubber rotor, twin, available as option for heavy-core granules Same as above but for Poly Cam
	09069508P 09069508PC	Resilient rubber rotor, 8" Same as above but for Poly Cam
	09074147P 09074147PC	Rotor, 8" stainless steel Same as above but for Poly Cam
	09073636-1 09072636-1 09073636-1C1	Bottom & slide, angle spout, standard w/insecticide 09S901 packages Bottom & slide, straight spout, one opening Bottom & slide, spout angled away from gauge
	09073636-2 09072636-2 09073636-2C1 09099926-2 09099926-2C1 09099926-2C2	Bottom & slide, angle spout, 2 opening standard on herbicide 09S902 packages Bottom & slide, straight spout, 2 opening Btm/slide, angled away from gauge, 2 opening Poly Bottom & slide, angle spout to cam, 2 opening Poly Bottom & slide, straight spout, 2 opening Poly Btm/slide, angled away from cam, 2 opening
	09073636-3 09072636-3 09073636-3C1 09099926-3 09099926-3C1 09099926-3C2	Bottom & slide, angle spout toward cam, 3 opening Bottom & slide, straight spout, 3 opening Btm/slide, spout angled away from cam, 3 opening Poly Bottom & slide, angle spout, 3 opening Poly Bottom & slide, straight spout, 3 opening Poly Btm/slide, angled away from cam, 3 opening
	09099926-4C1 09099926-4C2	Poly Bottom & slide, straight, 4 opening Poly Btm/slide, angled away from cam, 4 opening
	0908012-6 09073636-6	Spout only, Straight Spout only, Angled
	E09-06137	Spring Clip
	09066204	Tube Stabilizer
	0906646 0906646-3 0906949-3 N02-0009-040	14" Ro-Bander less cover (twin 7s) 7" Ro-Bander cover (requires 2 for 14" Ro-Bander) 5" Ro-Bander cover Ro-Bander decal

Applicator Dimensions - Discontinued Jumbo, Super & Junior

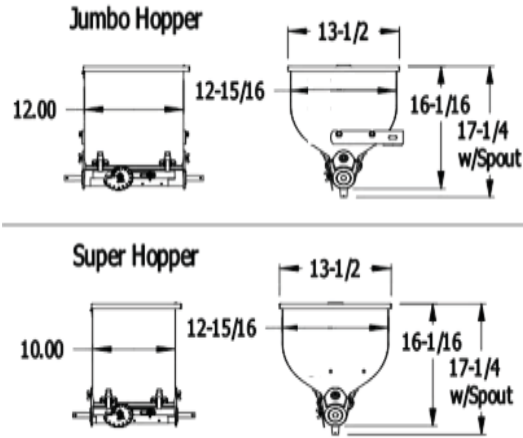

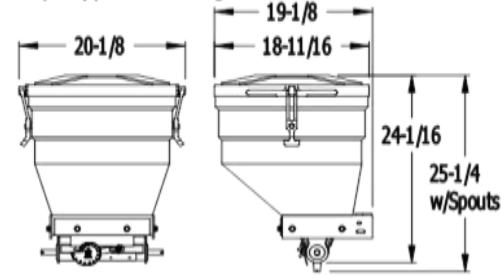

Poly Hopper Cam Gauge



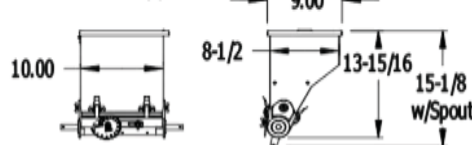



Junior Hopper



Rotor Bar Description

Rotor Bars for Jumbo Hoppers All Shafts 16-3/4 Long & 5/8 Diameter	
Steel Rotor Bars	Rubber Rotor Bars
Part# 0917422P 	Part# 09076719-C1P For 2-outlet Only 
	Part# 09070534P 

Rotor Bars for Super/Junior/Poly Cam Hoppers All Shafts 14-3/4 Long & 5/8 Diameter		
Steel Rotor Bars	Rubber Rotor Bars	
Part# 09074199P For 1-outlet Only 	Part# 09069507P For 1-outlet Only 	Part# 09069508P Part# 09069508PC 
Part# 09074147P Part# 09074147PC 	Part# 09076719P Part# 09076719PC For 2-outlet Only 	

“P” indicates rotor bar package with washers (steel & foam) for Steel Hoppers Only.

“PC” indicates rotor bar package with washers (steel & foam) for Poly Cam Hoppers Only.

Electric Motor Diagram

Wire Bag Part Number 09075589-A

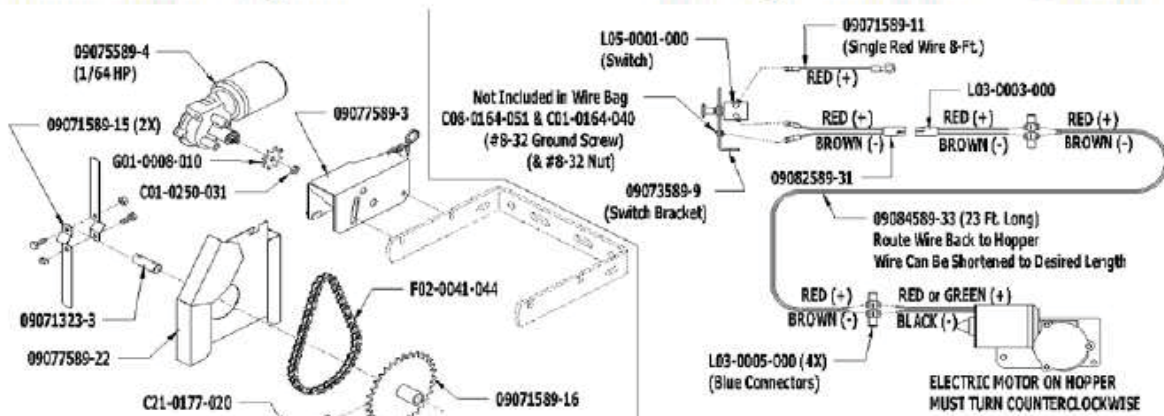

POLY FORAGE PRESERVATIVE APPLICATOR PACKAGES



Cam Gauge Metering of Forage Preservatives

- 2.3 cu. ft. polyethylene hopper
- Approximately 100-lbs. capacity at 45 lbs. per cu. ft. density
- Cam gauge metering with 2, 3 or 4 outlets
- U-frame mounting bracket with 1/2" holes and slots included
- Tubing and hose clamps are optional

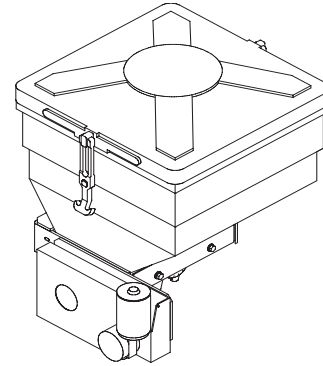

NOTE: Gandy Company does not supply rate charts for these additive or preservative products. Purchaser must consult the manufacturer for suggested rates and perform a field calibration check.

1 SELECT POLY FORAGE PRESERVATIVE APPLICATOR

Order No.	Description	Shp Wgt	List Price
09PC04WP12	100-lb. capacity hopper with four-outlets stainless steel bottom and slide, straight spouts, 8" rubber rotor, "U" frame bracket and two spout caps. 1/64 hp 12-volt motor assembled in place.	43 lbs.	\$ 968.00

2 SELECT DROP TUBE AND SPRING CLIPS

Order No.	Description	Shp Wgt	List Price
2406224-12	Plastic drop tube, 12 inches.	1 lbs.	\$ 5.00
2406224-108	Plastic drop tube, 9-feet.	3 lbs.	\$ 27.00
E09-06137	Spring clip to fasten tubing to spouts.	1 oz.	\$ 1.00

3 FIELD INSTALLED OPTIONS AND WEAR PARTS

Order No.	Description	Shp Wgt	List Price
09099948	Mounting for forage preservative applicator, hitch placement on round balers.		\$ 133.00

Con't. on next page

POLY FORAGE PRESERVATIVE APPLICATOR PACKAGES - CON'T.



Cam Gauge Metering of Forage Preservatives

3 CON'T. - FIELD INSTALLED OPTIONS AND WEAR PARTS

Order No.	Description	Shp Wgt	List Price
09072661	110-volt replacement motor drive, complete.		\$ 730.00
09075589-4	12-volt, 4 amp, 1/64 hp replacement motor only.	4 lbs.	\$ 182.00
09099926-2	Bottom and slide with two openings. Spouts angled toward cam gauge.		\$ 116.00
09099926-2C1	Bottom and slide with two openings. Straight spouts.		\$ 116.00
09099926-2C2	Bottom and slide with two openings. Spouts angled away from cam gauge.		\$ 116.00
09099926-3	Bottom and slide with three openings. Spouts angled toward cam gauge.		\$ 122.00
09099926-3C1	Bottom and slide with three openings. Straight spouts.		\$ 122.00
09099926-3C2	Bottom and slide with three openings. Spouts angled away from cam gauge.		\$ 122.00
09099926-4	Bottom and slide with four openings. Spouts angled toward cam gauge.		\$ 133.00
09099926-4C1	Bottom and slide with four openings. Straight spouts.		\$ 133.00
09099926-4C2	Bottom and slide with four openings. Spouts angled away from cam gauge.		\$ 133.00
0906375	Cam gauge.		\$ 6.00
09076719PC	Twin rubber rotor replacement package for two-outlet hopper. Use with heavy-core granules. Includes washers and O-rings.		\$ 82.00
09069508PC	Rubber 8-inch rotor bar replacement package. Includes washers, O-rings and spacers.		\$ 85.00
09074147PC	Stainless steel 8-inch rotor replacement package for one outlet hoppers. Includes washers, O-rings and spacers.		\$ 66.00
0908012-6	Replacement straight spout.		\$ 6.00
09073636-6	Replacement angled spout.		\$ 7.00

P45 FORAGE APPLICATORS



Cam Gauge Metering of Forage Preservatives

- 45-lb. capacity
- 1/64 hp 12-volt electric motor drive
- Poly applicators with cam gauge metering
- U-frame mounting bracket with 1/2" holes and slots included
- Optional extensions to increase capacity can be ordered for field installation

NOTE: Anertec & Gandy Company does not supply rate charts for these additive or preservative products. Purchaser must consult the manufacturer for suggested rates and perform a field calibration check. Mounting locations vary on implements and user may be required to fabricate mounting brackets.

1 SELECT A 45 LB. CAPACITY POLY APPLICATOR:

Order No.	Description	Shp Wgt	List Price
P451WP12	45-lb. capacity poly hopper with one-outlet stainless steel bottom and slide, straight spouts, an 8" rubber rotor bar, "U" frame mounting bracket and spout caps. 1/64 hp 12-volt motor assembled.	44 lbs.	\$ 618.00
P452WP12	45-lb. capacity poly hopper with two-outlet stainless steel bottom and slide, straight spouts, an 8" rubber rotor bar, "U" frame mounting bracket and spout caps. 1/64 hp 12-volt motor assembled.	45 lbs.	\$ 624.00
P453WP12	45-lb. capacity poly hopper with three-outlet stainless steel bottom and slide, straight spouts, an 8" rubber rotor bar, "U" frame mounting bracket and spout caps. 1/64 hp 12-volt motor assembled.	46 lbs.	\$ 639.00
P454WP12	45-lb. capacity poly hopper with four-outlet stainless steel bottom and slide, straight spouts, an 8" rubber rotor, "U" frame mounting bracket and two caps. 1/64 hp 12-volt motor assembled.	47 lbs.	\$ 644.00

P45 FORAGE APPLICATORS



Cam Gauge Metering of Forage Preservatives

2 SELECT DROP TUBE AND SPRING CLIPS

Order No.	Description	Shp Wgt	List Price
2406224-12	Plastic drop tube, 12 inches.		\$ 5.00
2406224-108	Plastic drop tube, 9-feet.		\$ 27.00
E09-06137	Spring clip to fasten tubing to spouts.	1 oz.	\$ 1.00

3 FIELD INSTALLED OPTIONS AND WEAR PARTS

Order No.	Description	Shp Wgt	List Price
P45-EXT	30-lb. capacity extension package with mounting hardware and silicone sealant		\$ 155.00
09075589-4	12-volt, 4 amp, 1/64 hp replacement motor only.	4 lbs.	\$ 182.00
09099926-2C1	Bottom and slide with two openings. Straight spouts.		\$ 116.00
09099926-3C1	Bottom and slide with three openings. Straight spouts.		\$ 122.00
09099926-4C1	Bottom and slide with four openings. Straight spouts.		\$ 133.00
0906375	Cam gauge.		\$ 6.00
09069508PC	Rubber 8-inch rotor replacement package for one outlet hoppers. Includes washers, O-rings and spacers.		\$ 85.00
0908012-6	Replacement straight spout.		\$ 6.00

100 LB. TALC AND INOCULANT APPLICATORS



Developed for Humus, Peat-Based Inoculants and Talc

Standard Equipment

- 2.3 cu. ft. capacity poly hopper
- Choice of 12-volt or 110-volt drive
- Special versions suitable for talcum powder application
- Adjustable slotted bottom gives application across the hopper's 14-inch width
- Developed for application of humus or peat-based inoculants in the field or at seed production facilities.

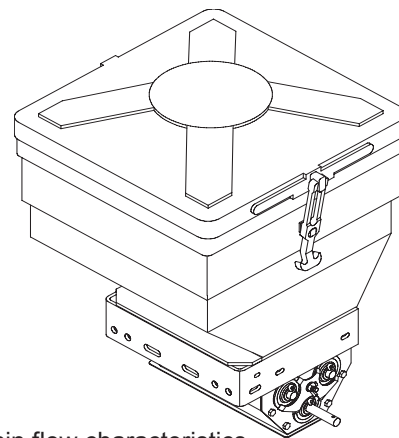

NOTE: Testing of material is always recommended for materials of uncertain flow characteristics. Rates can be adjusted by cam gauge, but unit is not recommended for critical or fine rates.

SPECIFICATIONS: 2.3 cu. ft. polyethylene hopper, lid with latches, three internal agitators, slotted bottom adjusted for size with cam gauge to meter material the width of the hopper. U-frame bracket with 1/2-inch holes and slots for mounting is included.

1 SELECT HUMUS OR PEAT-BASED INOCULANT APPLICATOR BELOW:

Order No.	Description	Shp Wgt	List Price
09099937	Adjustable Slotted Bottom Poly Applicator for humus or peat-based inoculants. Includes 110-volt motor.	75 lbs.	\$ 1,603.00

OR

CHOOSE TALC APPLICATOR BELOW:

Order No.	Description	Shp Wgt	List Price
09008961	Adjustable Slotted Bottom Poly Applicator for talc. Includes 12-volt motor drive.	75 lbs.	\$ 1,187.00
09TALC12CONV	Adjustable Slotted Bottom Poly Applicator for talc. Includes 12-volt motor AND 110-volt power converter	75 lbs.	\$ 1,562.00
09008962	Adjustable Slotted Bottom Poly Applicator for talc. Includes 110-volt motor.	75 lbs.	\$ 1,562.00

2 WEAR PARTS:

Order No.	Description	Shp Wgt	List Price
09099946	Latch package for poly hopper lid (replacement).		\$ 39.00
M05-0000-008	Rubber replacement latch only, 4".		\$ 18.00

P45 TALC APPLICATOR



Developed for Humus, Peat-Based Inoculants and Talc

Standard Equipment

- Applies talc in the field or at seed production facilities.
- 45-lb. capacity poly hopper
- Choice of 12-volt or 110-volt with power converter
- Adjustable slotted bottom gives application across the hopper's 14-inch width



NOTE: Testing of material is always recommended for materials of unknown composition. Application Rates can be adjusted by cam gauge, but unit is not recommended for critical or fine rates.

SPECIFICATIONS: 45-lb. capacity polyethylene hopper and lid with latches, three internal agitators, slotted bottom adjusted for size with cam gauge to meter material the width of the hopper. U-frame bracket with 1/2-inch holes and slots for surface mounting is included.

1 CHOOSE TALC APPLICATOR BELOW:

Order No.	Description	Shp Wgt	List Price
P45TALC12	Adjustable Slotted Bottom Poly Applicator for talc. Includes 12-volt motor drive.	75 lbs.	\$ 824.00
P45TALC12CONV	Adjustable Slotted Bottom Poly Applicator for talc. Includes 12-volt motor with 110-volt power converter	75 lbs.	\$ 1,236.00

2 FIELD INSTALLED OPTIONS AND WEAR PARTS:

Order No.	Description	Shp Wgt	List Price
P45-EXT	30-lb. capacity extension package with mounting hardware and silicone sealant		\$ 155.00
09099946	Latch package for poly hopper lid (replacement).		\$ 39.00
M05-0000-008	Rubber replacement latch only, 4".		\$ 18.00

65-SERIES SPREADERS

4, 5 and 6-foot Drop Spreaders with Tractor Tow Hitch

Spreads fertilizer, granular chemicals, granular lime and seed



Standard Equipment

- Precision-mated bottom & slide of cold milled steel
- Hand lever shutoff standard (optional hydraulic or electric available)
- Adjustable angle spread plate
- Optional jiggers to aid flow of material
- Choice of 16", 18", 20" and 26" tires
- Polyester powder-coated baked-on finish, green

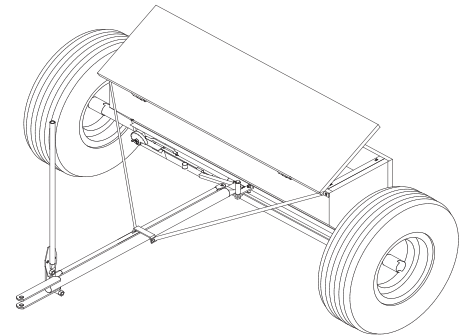

Specifications

Tires:	Choice of 16" pneumatic tires with steel rim, 18" high-flotation pneumatic tires with steel rim, 20" or 26" semi-pneumatic tires on steel disc rims
Capacities:	4-ft., 4 cu. ft. (113dm ³) or approximately 260 lbs. (116 kg); 5-ft., 5 cu. ft. (142dm ³) or approximately 325 lbs. (145 kg); 6-ft., 6 cu. ft. (170dm ³) or approximately 390 lbs. (174 kg)
6504 Wheel Spacing:	16" tires = 51"; 18" tires = 58-1/2"; 20" & 26" tires = 53-1/2"
6506 Wheel Spacing:	16" tires = 75"; 18" tires = 80-1/2"; 20" & 26" tires = 77-1/2"
6504 Overall Width:	16" tires = 59"; 18" tires = 66"; 20" and 26" tires = 58-1/4"
6505 Overall Width:	16" tires = 71"; 18" tires = 78"; 20" and 26" tires = 70-1/4"
6506 Overall Width:	16" tires = 83"; 18" tires = 90"; 20" and 26" tires = 82-1/4"

Con't. on next page

65-SERIES SPREADERS - CON'T.



4, 5 and 6-foot Drop Spreaders with Tractor Tow Hitch

Spreads fertilizer, granular chemicals, granular lime and seed

1 CHOOSE A DROP SPREADER

Order No.	Description	Shp Wgt	List Price
6504T16	4-ft. spreader with tractor hitch, hand-lever shutoff and 16" pneumatic tires on steel rim. Approximately 260 lbs., of capacity.	230 lbs.	\$ 1,659.00
6504T18	4-ft. spreader with tractor hitch, hand-lever shutoff and 18" high-flotation pneumatic tires on steel rim. Approximately 260 lbs., of capacity.	234 lbs.	\$ 1,779.00
6505T16	5-ft. spreader with tractor hitch, hand-lever shutoff and 16" pneumatic tires on steel rim. Approximately 325 lbs., of capacity.	273 lbs.	\$ 1,720.00
6505T18	5-ft. spreader with tractor hitch and 18" high-flotation pneumatic tires on steel rim. Approximately 325 lbs., of capacity.	277 lbs.	\$ 1,838.00
6506T16	6-ft. spreader with tractor hitch, hand-lever shutoff and 16" pneumatic tires on steel rim. Approximately 390 lbs., of capacity.	288 lbs.	\$ 1,779.00
6506T18	6-ft. spreader with tractor hitch, hand-lever shutoff and 18" high-flotation tires on steel rim. Approximately 390 lbs., of capacity.	313 lbs.	\$ 1,899.00

2 OPTIONAL FACTORY INSTALLED HYDRAULIC OR ELECTRIC SHUTOFF

Order No.	Description	Shp Wgt	List Price
659711	*Hydraulic shutoff attachment ILO of hand lever (factory installed - hydraulic hoses not included).	31 lbs.	\$ 418.00
6522	Electric shutoff attachment ILO of hand lever (factory installed).		\$ 853.00

*User supplies 1/4-inch hydraulic hoses from tractor to shutoff cylinder and 1/4-inch NPT fitting

Con't. on next page

65-SERIES SPREADERS - CON'T.

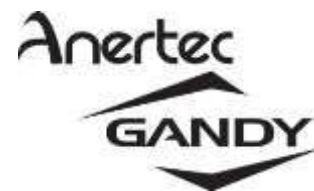

4, 5 and 6-foot Drop Spreaders with Tractor Tow Hitch

Spreads fertilizer, granular chemicals, granular lime and seed

3 FIELD INSTALLED OPTIONS

Order No.	Description	Shp Wgt	List Price
6521	Electric actuator shutoff attachment (field installed).	6 lbs.	\$ 901.00
069242	Tractor hitch bundle with lever shutoff	17 lbs.	\$ 223.00
0107813	Bolt-on hole closures, one per opening.		\$ 16.00
0107890	Deflectors for side dressing or banding.	4 oz.	\$ 71.00
0185214	4-ft. calibration pan.	1 lb.	\$ 70.00
01105214	5-ft. calibration pan.	6 lbs.	\$ 73.00
01125214	6-ft. calibration pan.	7 lbs.	\$ 76.00
657	Jiggler package, 4 ft.	8 lbs.	\$ 128.00
658	Jiggler package, 5 ft.	8 lbs.	\$ 146.00
659	Jiggler package, 6 ft.	9 lbs.	\$ 163.00

4 REPLACEMENT TIRE PACKAGES, HUB AND RIM

Order No.	Description	Shp Wgt	List Price
65A16	16" wheel package of two: steel hub and rims, pneumatic tire.	15 lbs.	\$ 221.00
65A18	18" wheel package of two: steel hub and rims, 1" bore with 18 x 8.5 x 8 4-ply tubeless high-flotation pneumatic tires.	42 lbs.	\$ 410.00
6518-4	Hub to adapt 15 x 5K rim for 6.70 x 15 tire for 6500 series spreader. 2 required.	6 lbs.	\$ 195.00
R01-0015-020	Rim only, 15 x 5K for 6.70 x 15 tire for greater clearance.	19 lbs.	\$ 78.00
R02-0015-010	Tire only, 6.70 x 15, 4-ply rib tubeless for greater clearance. Order 2 per spreader.	18 lbs.	\$ 163.00

5 WEAR PARTS

Order No.	Description	Shp Wgt	List Price
654-5	Bearing, end and center.	2 lbs.	\$ 55.00

65-SERIES SPREADERS

5 and 6-foot Drop Spreaders with 3-Pt. Hitch, End-Wheel Drive System

Spreads fertilizer, granular chemicals, granular lime and seed



Standard Equipment

- Hand-lever shutoff standard (optional hydraulic or electric shutoff available)
- Parking Stand
- Precision-mated bottom & slide of cold milled steel
- Adjustable angle spread plate
- Optional jigglers to aid flow of material
- Choice of 16", 18", 20" and 26" tires
- Polyester powder-coated baked-on finish, green

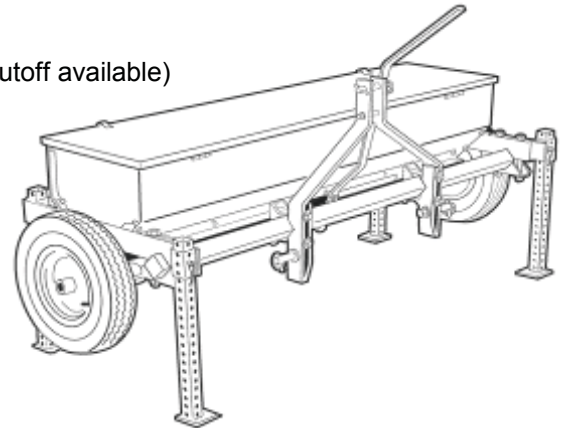

Specifications

Tires:	Choice of 16" pneumatic tires with steel rim, 18" high-flotation pneumatic tires with steel rim, 20" or 26" semi-pneumatic tires on steel disc rims
Hole Size:	1" openings on all spreaders. 25 openings spaced 2.260 inches (5.7cm) on 5-ft. model; 30 openings spaced 2.188-inches (5.5cm) on 6-ft.
Capacities:	5-ft., 5 cu. ft. (142dm ³) or approximately 325 lbs. (145 kg); 6-ft., 6 cu. ft. (170dm ³) or approximately 390 lbs. (174 kg)
Ground Clearance:	16" tires = 6"; 18" tires = 7"; 20" tires = 8"; 26" tires = 11" (for greater ground clearance 6.75 x 15 tires can be ordered)
6505 Wheel Spacing:	16" tires = 63"; 18" tires = 70-1/2"; 20" & 26" tires = 65-1/2"
6506 Wheel Spacing:	16" tires = 75"; 18" tires = 80-1/2"; 20" & 26" tires = 77-1/2"
6505 Overall Width:	16" tires = 71"; 18" tires = 78"; 20" & 26" tires = 70-1/4"
6506 Overall Width:	16" tires = 83"; 18" tires = 90"; 20" & 26" tires = 82-1/4"

Con't. on next page

65-SERIES SPREADERS - CON'T.



5 and 6-foot Drop Spreaders with 3-Pt. Hitch, End-Wheel Drive System

Spreads fertilizer, granular chemicals, granular lime and seed

1 CHOOSE A DROP SPREADER

Order No.	Description	Shp Wgt	List Price
6505TR16	5-ft. spreader, 3-pt. hitch, end-wheel drive, 16" pneumatic tires on steel rim.	361 lbs.	\$ 2,250.00
6505TR18	5-ft. spreader, 3-pt. hitch, end-wheel drive, 18" high flotation pneumatic tires on steel rim.	386 lbs.	\$ 2,367.00
6506TR16	6-ft. spreader, 3-pt. hitch, end-wheel drive, 16" pneumatic tires on steel rim.	381 lbs.	\$ 2,367.00
6506TR18	6-ft. spreader, 3-pt. hitch, end-wheel drive, 18" high-flotation pneumatic tires on steel rim.	406 lbs.	\$ 2,396.00

2 OPTIONAL FACTORY INSTALLED HYDRAULIC OR ELECTRIC SHUTOFF

Order No.	Description	Shp Wgt	List Price
659711	*Hydraulic shutoff attachment ILO of hand lever (factory installed - hydraulic hoses not included).	31 lbs.	\$ 418.00
6522	Electric shutoff attachment ILO of hand lever (factory installed).		\$ 853.00

*User supplies 1/4-inch hydraulic hoses from tractor to shutoff cylinder and 1/4-inch NPT fitting

3 FIELD INSTALLED OPTIONS

Order No.	Description	Shp Wgt	List Price
0107813	Bolt-on hole closures, one per opening.		\$ 16.00
0107890	Deflectors for side dressing or banding.	4 oz.	\$ 71.00
0185214	4-ft. calibration pan.	1 lb.	\$ 70.00
01105214	5-ft. calibration pan.	6 lbs.	\$ 73.00
01125214	6-ft. calibration pan.	7 lbs.	\$ 76.00
6521	Electric actuator shutoff attachment	6 lbs.	\$ 901.00
659711	Hydraulic shutoff attachment	31 lbs.	\$ 418.00
657	Jiggler package, 4 ft.	8 lbs.	\$ 128.00
658	Jiggler package, 5 ft.	8 lbs.	\$ 146.00
659	Jiggler package, 6 ft.	9 lbs.	\$ 163.00

Con't. on next page

65-SERIES SPREADERS - CON'T.



5 and 6-foot Drop Spreaders with 3-Pt. Hitch, End-Wheel Drive System

Spreads fertilizer, granular chemicals, granular lime and seed

4 REPLACEMENT TIRE PACKAGES, HUB AND RIM

Order No.	Description	Shp Wgt	List Price
65A16	16" wheel package of two: steel hub and rims, pneumatic tire.	15 lbs.	\$ 221.00
65A18	18-inch wheel package of two: steel hub and rims, 1-inch bore with 18 x 8.5 x 8, 4-ply tubeless high-flotation pneumatic tires.	42 lbs.	\$ 410.00
6518-4	Hub to adapt 15 x 5K rim for 6.70 x 15 tire for 6500 series spreader. 2 required.	6 lbs.	\$ 195.00
R01-0015-020	Rim only, 15 x 5K for 6.70 x 15 tire for greater clearance.	19 lbs.	\$ 78.00
R02-0015-010	Tire only, 6.70 x 15, 4-ply rib tubeless for greater clearance. Order 2 per spreader.	18 lbs.	\$ 163.00

5 WEAR PARTS

Order No.	Description	Shp Wgt	List Price
654-5	Bearing, end & center.	2 lbs.	\$ 55.00

65-SERIES SPREADERS

4, 5 and 6-foot Drop Spreaders with 3-Pt. Hitch

Spreads fertilizer, granular chemicals, granular lime and seed



Standard Equipment

- Hand-lever shutoff standard - optional hydraulic or electric shutoff available
- Precision-mated bottom & slide of cold milled steel
- Parking Stand
- Adjustable angle spread plate
- Optional jiggers to aid flow of material
- Polyester powder-coated baked-on finish, green

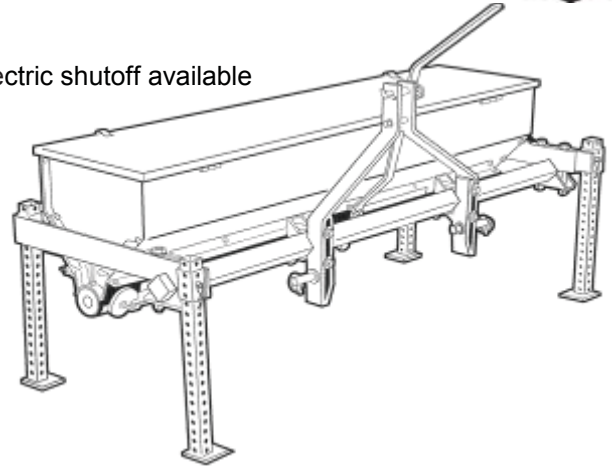

Specifications

Hole Size: 1" openings on all spreaders. 20 openings spaced 2.352-inches (6cm) on 4-ft. model; 25 openings spaced 2.260 inches (5.7cm) on 5-ft. model; 30 openings spaced 2.188-inches (5.5cm) on 6-ft.

Capacities: 4-ft., 4 cu. ft. (113dm³) or approximately 260 lbs. (116 kg); 5-ft., 5 cu. ft. (142dm³) or approximately 325 lbs. (145 kg); 6-ft., 6 cu. ft. (170dm³) or approximately 390 lbs. (174 kg)

6504 Overall Width: 16" tires = 59"; 18" tires = 66"; 20" & 26" tires = 58-1/4"

6505 Overall Width: 16" tires = 71"; 18" tires = 78"; 20" & 26" tires = 70-1/4"

6506 Overall Width: 16" tires = 83"; 18" tires = 90"; 20" & 26" tires = 82-1/4"

1 CHOOSE A DROP SPREADER

Order No.	Description	Shp Wgt	List Price
6504PTH	4-ft. spreader with 3-pt. hitch and hand-lever shutoff. Choose a hydraulic or electric drive system in step #3.	319 lbs.	\$ 1,711.00
6505PTH	5-ft. spreader with 3-pt. hitch and hand-lever shutoff. Choose a hydraulic or electric drive system in step #3.	354 lbs.	\$ 1,785.00
6506PTH	6-ft. spreader with 3-pt. hitch and hand-lever shutoff. Choose a hydraulic or electric drive system in step #3.	395 lbs.	\$ 1,838.00

Con't. on next page

65-SERIES SPREADERS - CON'T.

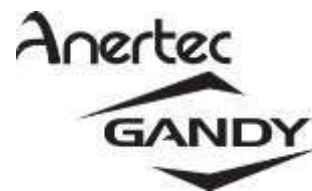

4, 5 and 6-foot Drop Spreaders with 3-Pt. Hitch
 Spreads fertilizer, granular chemicals, granular lime and seed

2 OPTIONAL FACTORY INSTALLED HYDRAULIC OR ELECTRIC SHUTOFF

Order No.	Description	Shp Wgt	List Price
659711	*Hydraulic shutoff attachment ILO of hand lever (factory installed - hydraulic hoses not included).	31 lbs.	\$ 418.00
6522	Electric shutoff attachment ILO of hand lever (factory installed).		\$ 853.00

*User supplies 1/4-inch hydraulic hoses from tractor to shutoff cylinder and 1/4-inch NPT fitting

3 SELECT A HYDRAULIC OR ELECTRIC DRIVE SYSTEM

Order No.	Description	Shp Wgt	List Price
6512	*Hydraulic drive package, less hoses for 3-pt. hitch.	28 lbs.	\$ 950.00
6513	Electric drive package, 12V for 3-pt. hitch.	28 lbs.	\$ 1,082.00

*User supplies 1/4-inch hydraulic hoses from tractor to shutoff cylinder and 1/4-inch NPT fitting

4 FIELD INSTALLED OPTIONS

Order No.	Description	Shp Wgt	List Price
0107813	Bolt-on hole closures, one per opening.		\$ 16.00
0107890	Deflectors for side dressing or banding.	4 oz.	\$ 71.00
6521	Electric actuator shutoff attachment retrofit (field installed).	6 lbs.	\$ 901.00
0185214	4-ft. calibration pan.	1 lb.	\$ 70.00
01105214	5-ft. calibration pan.	6 lbs.	\$ 73.00
01125214	6-ft. calibration pan.	7 lbs.	\$ 76.00
657	Jiggler package, 4 ft.	8 lbs.	\$ 128.00
658	Jiggler package, 5 ft.	8 lbs.	\$ 146.00
659	Jiggler package, 6 ft.	9 lbs.	\$ 163.00

5 WEAR PARTS

Order No.	Description	Shp Wgt	List Price
654-5	Bearing, end and center.	2 lbs.	\$ 55.00

65-SERIES ASB SPREADER



4 and 6-foot Drop Spreaders with Adjustable Slotted Bottom

For spreading agricultural lime and crumb rubber

Standard Equipment

- Slotted, stainless steel bottom
- Specially designed rotor bar to agitate lime
- Choice of push-handle or tow-hitch on 4-ft model
- Tow-hitch only on 6-ft. model
- Choice of 16" or 18" pneumatic tires
- Polyester powder-coated baked-on finish, green

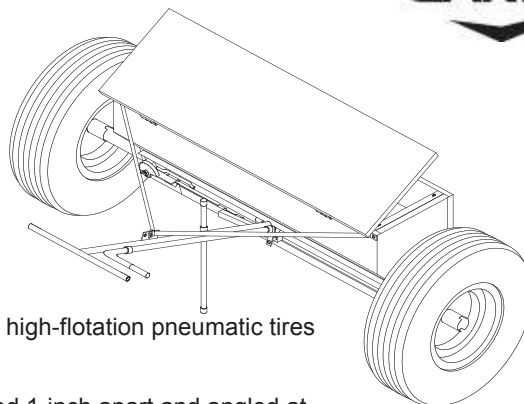

Specifications

Tires: Choice of 16" pneumatic tires or 18" high-flotation pneumatic tires on steel rim

Slot Size: 3-3/4" x 3/4" slotted openings spaced 1-inch apart and angled at 30-degrees. 12 openings on 4-ft. model and 19 openings on 6-ft. model

Capacities: 4-ft., 4 cu. ft. (113dm³) or approximately 260 lbs. (116 kg); 6-ft., 6 cu. ft. (170dm³) or approximately 390 lbs. (1745 kg)

Ground Clearance: 16" tires = 6"; 18" tires = 7"

6504 Wheel Spacing: 16" tires = 51"; 18" tires = 58-1/2"

6506 Wheel Spacing: 16" tires = 75"; 18" tires = 87-1/2"

6504 Overall Width: 16" tires = 59"; 18" tires = 66"

6506 Overall Width: 16" tires = 83"; 18" tires = 90"

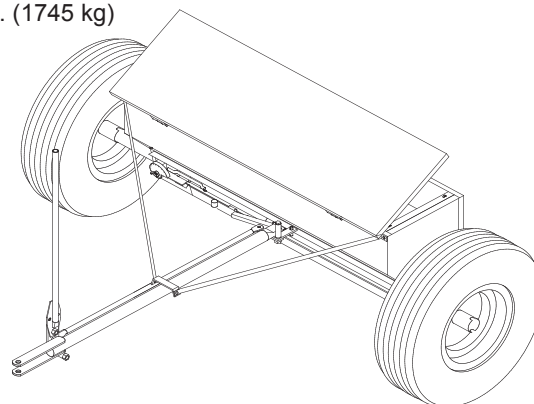

1 CHOOSE A DROP SPREADER

Order No.	Description	Shp Wgt	List Price
6504ASB16H	4-ft. spreader, 260 lb. approximate capacity with stainless steel adjustable slotted bottom, push-handle and 16" pneumatic tires on steel rims.	230 lbs.	\$ 2,087.00
6504ASB18H	4-ft. spreader, 260 lb. approximate capacity with stainless steel adjustable slotted bottom, push-handle and 18" high-flotation pneumatic tires on steel rims	234 lbs.	\$ 2,208.00
6504ASB16T	4-ft. spreader, 260 lb. approximate capacity with stainless steel adjustable slotted bottom, tow-hitch and 16" pneumatic tires on steel rims.	218 lbs.	\$ 2,189.00
6504ASB18T	4-ft. spreader, 260 lb. approximate capacity with stainless steel adjustable slotted bottom, tow-hitch and 18" high-flotation pneumatic tires on steel rims.	242 lbs.	\$ 2,310.00
6506ASB16T	6-ft. spreader, 390 lb. approximate capacity with stainless steel adjustable slotted bottom, tow-hitch and 16" pneumatic tires on steel rims.	273 lbs.	\$ 2,418.00
6506ASB18T	6-ft. spreader, 390 lb. approximate capacity with stainless steel adjustable slotted bottom, tow-hitch and 18" high-flotation pneumatic tires on steel rims.	277 lbs.	\$ 2,549.00

Con't. on next page

65-SERIES ASB SPREADER - CON'T



4 and 6-foot Drop Spreaders with Adjustable Slotted Bottom

For spreading agricultural lime and crumb rubber

2 REPLACEMENT TIRE PACKAGES, HUB AND RIM

Order No.	Description	Shp Wgt	List Price
65A16	16-inch wheel package of two: steel hub and rims, pneumatic tire.	15 lbs.	\$ 221.00
65A18	18-inch wheel package of two: steel hub and rims, 1" bore with 18 x 8.5 x 8 4-ply tubeless high-flotation pneumatic tires.	42 lbs.	\$ 410.00
6518-4	Hub to adapt 15 x 5K rim for 6.70 x 15 tire for 6500 series spreader. 2 required.	6 lbs.	\$ 189.00
R01-0015-020	Rim only, 15 x 5K for 6.70 x 15 tire for greater clearance.	19 lbs.	\$ 78.00
R02-0015-010	Tire only, 6.70 x 15, 4-ply rib tubeless for greater clearance. Order 2 per spreader.	18 lbs.	\$ 163.00
654-5	Bearing, center.	2 lbs.	\$ 55.00
6524-8	Bearing, end.	2 lbs.	\$ 124.00

3 OPTIONAL JIGGLER KITS

Order No.	Description	Shp Wgt	List Price
657	Jiggler package for 4-ft. spreader (jigglers not recommended for ag lime or similar products).	8 lbs.	\$ 128.00
659	Jiggler package for 6-ft. spreader (jigglers not recommended for ag lime or similar products).	9 lbs.	\$ 163.00

4 RETROFIT KITS FOR EXISTING 4 AND 6-FT 65-SERIES SPREADERS

Order No.	Description	Shp Wgt	List Price
6524	Adjustable slotted bottom retrofit kit for existing 4-ft variable rate drop spreaders.		\$ 1,020.00
6526	Adjustable slotted bottom retrofit kit for existing 6-ft variable rate drop spreaders.		\$ 1,257.00

10T SERIES SPREADERS

6, 8, 10 and 12-Foot Spreaders with Tractor Tow Hitch

For spreading fertilizer, granular limestone and seed



Standard Equipment

- Hot-rolled steel removable hopper bottom and hinged rate-control slide
- Shur-feed rotors; hand-removable stub drive for rotor
- Adjustable spread plate
- Hand lever shutoff standard (optional hydraulic or electric available)
- Weather-tight removable and reversible covers with spill-guards and dual lock-down latches for each cover
- 15 x 5K rims standard
- Powder angles included
- Low speed bearings standard; high-speed bearings for road speeds optional
- Heavy-duty tractor hitch with extension at rear for trailing non-ground engaging machines
- Operator's manual and rate charts included

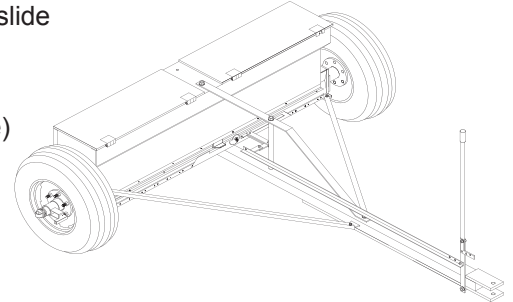

Specifications

- Capacity: 1.5 cubic feet per ft. of hopper length; approx. 100 lbs./ft.
 Bottom/Slide: Diamond-shaped openings 1-1/2" long, spaced 4" apart
 Overall Height: 36"
 Overall Length: 90"
 Clearance: 13" above ground; approx. 6" with spread plate
 Rims: 15 x 5K 6-bolt rims included; 15 x 10K rims optional for flotation tires.
 - rims can be "dished-out" for 5-inch wider wheel spacing
 Tires: Optional

1 CHOOSE A SPREADER

Order No.	Description	Shp Wgt	List Price
1006T	6-foot Spreader. Approximate hopper capacity, 600 pounds. 9 cu. ft. Wheel tread 86 inches (with wheels "dished in"). Overall width, 99 inches. 18 openings.	515 lbs.	\$ 4,153.00
1008T	8-foot Spreader. Approximate hopper capacity, 800 pounds. 12 cu. ft. Wheel tread 110 inches (with wheels "dished in"). Overall width, 123 inches. 24 openings	598 lbs.	\$ 4,503.00
1010T	10-foot Spreader. Approximate hopper capacity, 1,000 pounds. 15 cu. ft. Wheel tread 134 inches (with wheels "dished in"). Overall width, 147 inches. 30 openings.	648 lbs.	\$ 4,926.00
1012T	12-foot Spreader. Approximate hopper capacity, 1,200 pounds. 18 cu. ft. Wheel tread 158 inches (with wheels "dished in"). Overall width, 171 inches. 36 openings.	753 lbs.	\$ 5,365.00

Con't. on next page

10T SERIES SPREADERS CON'T.

6, 8, 10 and 12-Foot Spreaders with Tractor Tow Hitch

For spreading fertilizer, granular limestone and seed



2 CONVERT HAND LEVER SHUTOFF TO OPTIONAL HYDRAULIC OR ELECTRIC SHUTOFF

Order No.	Description	Shp Wgt	List Price
3209743A	*Hydraulic shutoff cylinder and mounting in lieu of hand lever. Factory installed.	5 lbs.	\$ 249.00
0101104	Electric actuator shutoff and mounting in lieu of hand lever. Factory installed.		\$ 763.00

*User supplies 1/4-inch hydraulic hoses from tractor to shutoff cylinder and 1/4-inch NPT fitting

3 LOW SPEED BEARING BEARINGS INCLUDED IN BASE; OPTIONAL HIGH-SPEED BEARING BELOW:

Order No.	Description	Shp Wgt	List Price
0102105	Heavy-duty hub/axle for road speeds.		\$ 851.00
0102107	<i>Deduct std. hub & axle when ordering HD hub and axle</i>		\$ (585.00)

4 15 x 5K 6-BOLT RIMS INCLUDED IN BASE PRICE; OPTIONAL 15 X 10K BELOW:

Order No.	Description	Shp Wgt	List Price
R01-0015-030	Rim only 15 x 10K (for high-flotation tire - No. 11L15) two required.	30 lbs.	\$ 116.00
R01-0015-020	<i>Deduct 2, 15 x 5K rims when ordering R01-0015-030</i>		\$ (75.00)

5 10T SERIES SHIPS WITHOUT TIRES - OPTIONAL TIRES LISTED BELOW:

Order No.	Description	Shp Wgt	List Price
R02-0015-010	6.75 x 15, 4-ply rib implement tubeless tire. Uses standard 15 x 5K rims included in base. Order two (2) tires per spreader.	18 lbs.	\$ 163.00
R02-0015-020	11L15, 6-ply tubeless tire. Requires R01-0015-030 rim. Order two (2) tires per spreader.	30 lbs.	\$ 190.00

Con't. on next page

10T SERIES SPREADERS CON'T.

6, 8, 10 and 12-Foot Spreaders with Tractor Tow Hitch

For spreading fertilizer, granular limestone and seed



6 FIELD INSTALLED OPTIONS

Order No.	Description	Shp Wgt	List Price
0185214	Calibration pan, 4-ft. for 8-ft. spreader (order 2 per unit).	6 lbs.	\$ 70.00
01105214	Calibration pan, 5-ft. for 10-ft. spreader (order 2 per unit).	8 lbs.	\$ 73.00
01125214	Calibration pan, 6-ft. for 12-ft. spreader (order 2 per unit).	11 lbs.	\$ 76.00
0108013	Clamp-on hole closure.		\$ 13.00
0108190	Deflectors, side-dressing or banding.	3 lbs.	\$ 72.00
0101103	Electric actuator shutoff.		\$ 858.00
3209743	Hydraulic cylinder & mounting as an extra when hopper has hand lever in place.		\$ 405.00
3209742	Hydraulic cylinder only.	5 lbs.	\$ 322.00
3209742R	Hydraulic cylinder repair kit.	5 lbs.	\$ 44.00
0197102	Manual holder package option for units not so equipped.		\$ 44.00
0566394-T	Powder angle package for 6-ft. "T" series, standard equipment, as an extra.	2 lbs.	\$ 82.00
0586394-T	Powder angle package for 8-ft. "T" series, standard equipment, as an extra.	2.5 lbs.	\$ 98.00
05106394-T	Powder angle package for 10-ft. "T" series, standard equipment, as an extra.	3 lbs.	\$ 106.00
05127694-T	Powder angle package for 12-ft. "T" series, standard equipment, as an extra.	3.5 lbs.	\$ 115.00
5708210	Spout holder package, centered angle spout only, order one per outlet.	1 lbs.	\$ 18.00

Conversion packages to T-series for discontinued spreaders are listed below. To ensure correct rate chart usage, please note that:

Current Production Model: 10T Series has 1-1/2 inch openings spaced 4-inches apart

10 Series has 2-inch openings spaced 6-inches apart

10A Series has 1-1/2 inch openings spaced 3-3/8 inches apart

10S Series has 1-1/2 inch openings spaced 6-inches apart

RETROFIT KITS

Order No.	Description	Shp Wgt	List Price
0568011&12PKG	Retrofit 10T bottom, slide & rotor package, 6 ft. for discontinued 1006 & 1006A models.	103 lbs.	\$ 957.00
0588011&12PKG	Retrofit 10T bottom, slide & rotor package, 8 ft. for discontinued 1008 & 1008A models.	122 lbs.	\$ 1,108.00
05108011&12PKG	Retrofit 10T bottom, slide & rotor package, 10 ft. for discontinued 1010 & 1010A models.	142 lbs.	\$ 1,289.00
05128011&12PKG	Retrofit 10T bottom, slide & rotor package, 12 ft. for discontinued 1012 & 1012A models.	164 lbs.	\$ 1,468.00

10TR SERIES SPREADERS



6, 8, 10 and 12-Foot Spreaders with 3-Pt. Hitch, End-Wheel Drive with Hydraulic Shutoff and Parking Stand

For spreading fertilizer, granular limestone and seed

Standard Equipment

- Category II, 3-pt. hitch 10TR series
- Hydraulic shutoff (User supplies 1/4-inch hydraulic hoses and 1/4-inch NPT pipe thread fitting)
- Parking stand
- End wheel drive turns rotor in each side
- Powder angles and adjustable spread plate
- Hot-rolled steel removable hopper bottom and hinged rate-control slide
- Shur-feed rotors; hand-removable stub drive for rotor
- Weather-tight removable and reversible covers with spill-guards and dual lock-down latches for each cover
- Low speed bearings standard; high-speed bearings for road speeds optional
- Operator's manual and rate charts

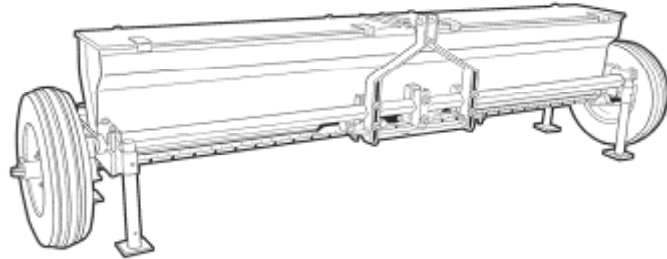

Specifications

- Capacity: 1.5 cubic feet per ft. of hopper length; approx. 100 lbs./ft.
 Bottom/Slide: Diamond-shaped openings 1-1/2" long, spaced 4" apart
 Overall Height: 36"
 Overall Length: 90"
 Clearance: 13" above ground; approx. 6" with spread plate
 Rims: 15 x 5K 6-bolt rims included; 15 x 10K rims optional for flotation tires.
 - rims can be "dished-out" for 5-inch wider wheel spacing
 Tires: Optional

1 CHOOSE A SPREADER

Order No.	Description	Shp Wgt	List Price
1006TR	6-foot Spreader. Cat. II, 3-pt. hitch. Hydraulic shutoff (hydraulic hoses not included user supplies 1/4-inch hoses and 1/4"-NPT pipe thread fitting). Parking stand. Approximate hopper capacity, 600 pounds. 9 cu. ft. Wheel tread 87 inches (with wheels "dished in"). Overall width, 100 inches. 18 openings.	613 lbs.	\$ 5,343.00
1008TR	8-foot Spreader. Cat. II, 3-pt. hitch. Hydraulic shutoff (hydraulic hoses not included user supplies 1/4-inch hoses and 1/4"-NPT pipe thread fitting). Parking stand. Approximate hopper capacity, 800 pounds. 12 cu. ft. Wheel tread 111 inches (with wheels "dished in"). Overall width, 124 inches. 24 openings.	703 lbs.	\$ 5,607.00

Con't. on next page

10TR SERIES SPREADERS CON'T.



6, 8, 10 and 12-Foot Spreaders with 3-Pt. Hitch, End-Wheel Drive with Hydraulic Shutoff and Parking Stand

For spreading fertilizer, granular limestone and seed

1 CON'T. - CHOOSE A SPREADER

Order No.	Description	Shp Wgt	List Price
1010TR	10-foot Spreader. Cat. II, 3-pt. hitch. Hydraulic shutoff (hydraulic hoses not included - user supplies 1/4-inch hoses and 1/4"-NPT pipe thread fitting). Parking stand. Approximate hopper capacity, 1,000 pounds. 15 cu. ft. Wheel tread 135 inches (with wheels "dished in"). Overall width, 148 inches. 30 openings.	802 lbs.	\$ 5,871.00
1012TR	12-foot Spreader. Cat. II, 3-pt. hitch. Hydraulic shutoff (hydraulic hoses not included - user supplies 1/4-inch hoses and 1/4"-NPT pipe thread fitting). Parking stand. Approximate hopper capacity, 1,200 pounds. 18 cu. ft. Wheel tread 158 inches (with wheels "dished in"). Overall width, 172 inches. 36 openings.	903 lbs.	\$ 6,135.00

2 10TR SERIES SHIPS WITHOUT TIRES - OPTIONAL TIRES LISTED BELOW:

Order No.	Description	Shp Wgt	List Price
R02-0015-010	6.75 x 15, 4-ply rib implement tubeless tire. Uses standard 15 x 5K rims included in base . Order 2 per spreader.	18 lbs.	\$ 163.00
R02-0015-020	11L15, 6-ply tubeless tire. Requires R01-0015-030 rim. Order 2 per spreader.	30 lbs.	\$ 190.00

3 FIELD INSTALLED OPTIONS

Order No.	Description	Shp Wgt	List Price
0185214	Calibration pan, 4-ft. for 8-ft. spreader (order 2 per unit).	6 lbs.	\$ 70.00
01105214	Calibration pan, 5-ft. for 10-ft. spreader (order 2 per unit).	8 lbs.	\$ 73.00
01125214	Calibration pan, 6-ft. for 12-ft. spreader (order 2 per unit).	11 lbs.	\$ 76.00
0108013	Clamp-on hole closure.		\$ 13.00
0108190	Deflectors for side-dressing or banding.	3 lbs.	\$ 72.00
3209743	Hydraulic cylinder & mounting as an extra when hopper has hand lever in place.		\$ 405.00
3209742	Hydraulic cylinder only.	5 lbs.	\$ 322.00
3209742R	Hydraulic cylinder repair kit.	5 lbs.	\$ 44.00
0197102	Manual holder package option for units not so equipped.		\$ 44.00
0566394-T	Powder angle package for 6-ft. "T" series, standard equipment, as an extra.	2 lbs.	\$ 82.00
0586394-T	Powder angle package for 8-ft. "T" series, standard equipment, as an extra.	2.5 lbs.	\$ 98.00
05106394-T	Powder angle package for 10-ft. "T" series, standard equipment, as an extra.	3 lbs.	\$ 106.00
05127694-T	Powder angle package for 12-ft. "T" series, standard equipment, as an extra.	3.5 lbs.	\$ 115.00
5708210	Spout holder package, centered angle spout only, order one per outlet.	1 lbs.	\$ 18.00

Con't. on next page

10TR SERIES SPREADERS CON'T.

6, 8, 10 and 12-Foot Spreaders with 3-Pt. Hitch, End-Wheel Drive with Hydraulic Shutoff and Parking Stand

For spreading fertilizer, granular limestone and seed



Conversion packages to T-series for discontinued spreaders are listed below. To ensure correct rate chart usage, please note that:

- Current Production Model: 10T Series has 1-1/2 inch openings spaced 4-inches apart
- 10 Series has 2-inch openings spaced 6-inches apart
- 10A Series has 1-1/2 inch openings spaced 3-3/8 inches apart
- 10S Series has 1-1/2 inch openings spaced 6-inches apart

RETROFIT KITS

Order No.	Description	Shp Wgt	List Price
0568011&12PKG	Retrofit 10T bottom, slide & rotor package, 6 ft. for discontinued 1006 &1006A models.	103 lbs.	\$ 957.00
0588011&12PKG	Retrofit 10T bottom, slide & rotor package, 8 ft. for discontinued 1008 &1008A models.	122 lbs.	\$ 1,108.00
05108011&12PKG	Retrofit 10T bottom, slide & rotor package, 10 ft. for discontinued 1010 & 1010A models.	142 lbs.	\$ 1,289.00
05128011&12PKG	Retrofit 10T bottom, slide & rotor package, 12 ft. for discontinued 1012 & 1012A models.	164 lbs.	\$ 1,468.00

10T-PTH SERIES SPREADERS



6, 8, 10 and 12-Foot Spreaders with 3-Pt. Hitch and Hydraulic Shutoff

For spreading fertilizer, granular limestone and seed

Standard Equipment

- 3-pt. hitch
- Parking Stands
- Powder angles and adjustable spread plate included
- Hot-rolled steel removable hopper bottom and hinged rate-control slide
- Shur-feed rotors; hand-removable stub drive for rotor
- Weather-tight removable and reversible covers with spill-guards and dual lock-down latches for each cover
- Hydraulic shutoff (User supplies 1/4-inch hydraulic hoses and 1/4-inch NPT pipe thread fitting)
- Operator's manual and rate charts included

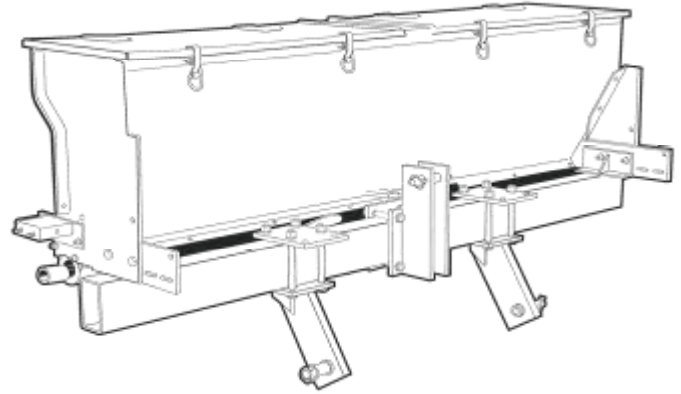

Specifications

Capacity: 1.5 cubic feet per ft. of hopper length; approx. 100 lbs./ft.
 Bottom/Slide: Diamond-shaped openings 1-1/2" long, spaced 4" apart
 Overall Height: 36"
 Overall Length: 90"
 Clearance: 13" above ground; approx. 6" with spread plate

1 CHOOSE A SPREADER

Order No.	Description	Shp Wgt	List Price
1006T-PTH	6-foot Spreader. Bottom with 1-1/2 inch holes spaced 4-inches apart, powder angles, mounting brackets, parking stand and *hydraulic shutoff. Approximate hopper capacity of 600 pounds. 9 cu. ft. 18 openings.	613 lbs.	\$ 4,520.00
1008T-PTH	8-foot Spreader. Bottom with 1-1/2 inch holes spaced 4-inches apart, powder angles, mounting brackets, parking stand and *hydraulic shutoff. Approximate hopper capacity of 800 pounds. 12 cu. ft. 24 openings.	703 lbs.	\$ 4,817.00
1010T-PTH	10-foot Spreader. Bottom with 1-1/2 inch holes spaced 4-inches apart, powder angles, mounting brackets, parking stand and *hydraulic shutoff. Approximately hopper capacity of 1,000 pounds. 15 cu. ft. 30 openings.	802 lbs.	\$ 5,224.00
1012T-PTH	12-foot Spreader. Bottom with 1-1/2 inch holes spaced 4-inches apart, powder angles, mounting brackets, parking stand and *hydraulic shutoff. Approximately hopper capacity of 1,200 pounds. 18 cu. ft. 36 openings.	903 lbs.	\$ 5,487.00

*User supplies 1/4-inch hydraulic hoses from tractor to shutoff cylinder and 1/4-inch NPT fitting

Con't. on next page

10T-PTH SERIES SPREADERS CONTINUED



6, 8, 10 and 12-Foot Spreaders with 3-Pt. Hitch and Hydraulic Shutoff

For spreading fertilizer, granular limestone and seed

2 CHOOSE A HYDRAULIC OR ELECTRIC DRIVE PACKAGE

Order No.	Description	Shp Wgt	List Price
57082100	*Hydraulic drive pkg., less hoses, 15-gallon flow	22 lbs.	\$ 817.00
57094108	Electric drive package, 12V, 11-13 amps	54 lbs.	\$ 1,310.00

*User supplies 1/2-inch hydraulic hoses from tractor to drive and 1/2-inch NPT fitting

3 FIELD INSTALLED OPTIONS

Order No.	Description	Shp Wgt	List Price
0185214	Calibration pan, 4-ft. for 8-ft. spreader (order 2 per unit).	6 lbs.	\$ 70.00
01105214	Calibration pan, 5-ft. for 10-ft. spreader (order 2 per unit).	8 lbs.	\$ 73.00
01125214	Calibration pan, 6-ft. for 12-ft. spreader (order 2 per unit).	11 lbs.	\$ 76.00
0108013	Clamp-on hole closure.		\$ 13.00
0108190	Deflectors, side-dressing or banding.	3 lbs.	\$ 72.00
0101103	Electric actuator shutoff.		\$ 858.00
3209742	Hydraulic cylinder only.	5 lbs.	\$ 322.00
3209742R	Hydraulic cylinder repair kit.	5 lbs.	\$ 44.00
57082105	Hydraulic hose package - connects hydraulic shutoff cylinder to hydraulic drive motor	5 lbs.	\$ 225.00
0197102	Manual holder package option for units not so equipped.		\$ 44.00
0566394-T	Powder angle package for 6-ft. "T" series, standard equipment, as an extra.	2 lbs.	\$ 82.00
0586394-T	Powder angle package for 8-ft. "T" series, standard equipment, as an extra.	2.5 lbs.	\$ 98.00
05106394-T	Powder angle package for 10-ft. "T" series, standard equipment, as an extra.	3 lbs.	\$ 106.00
05127694-T	Powder angle package for 12-ft. "T" series, standard equipment, as an extra.	3.5 lbs.	\$ 115.00
5708210	Spout holder package, centered angle spout only, order one per outlet.	1 lbs.	\$ 18.00

Con't. on next page

10T-PTH SERIES SPREADERS CONTINUED



6, 8, 10 and 12-Foot Spreaders with 3-Pt. Hitch and Hydraulic Shutoff

For spreading fertilizer, granular limestone and seed

Conversion packages to T-series for discontinued spreaders are listed below. To ensure correct rate chart usage, please note that:

Current Production Model: 10T Series has 1-1/2 inch openings spaced 4-inches apart

10 Series has 2-inch openings spaced 6-inches apart

10A Series has 1-1/2 inch openings spaced 3-3/8 inches apart

10S Series has 1-1/2 inch openings spaced 6-inches apart

RETROFIT KITS

Order No.	Description	Shp Wgt	List Price
0568011&12PKG	Retrofit 10T bottom, slide & rotor package, 6 ft. for discontinued 1006 &1006A models.	103 lbs.	\$ 957.00
0588011&12PKG	Retrofit 10T bottom, slide & rotor package, 8 ft. for discontinued 1008 &1008A models.	122 lbs.	\$ 1,108.00
05108011&12PKG	Retrofit 10T bottom, slide & rotor package, 10 ft. for discontinued 1010 & 1010A models.	142 lbs.	\$ 1,289.00
05128011&12PKG	Retrofit 10T bottom, slide & rotor package, 12 ft. for discontinued 1012 & 1012A models.	164 lbs.	\$ 1,468.00

10T-TBM SERIES SPREADERS

6, 8, 10 and 12-Foot Spreaders for Implement Mount

For spreading fertilizer, granular limestone and seed

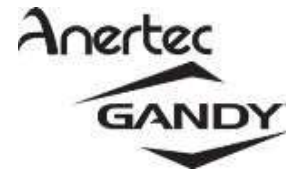

Standard Equipment

- Implement mounted
- Powder angles and adjustable spread plate included
- Hot-rolled steel removable hopper bottom and hinged rate-control slide
- Shur-feed rotors; hand-removable stub drive for rotor
- Weather-tight removable and reversible covers and dual lock-down latches for each cover
- Electric or hydraulic drive
- Operator's manual and rate charts included

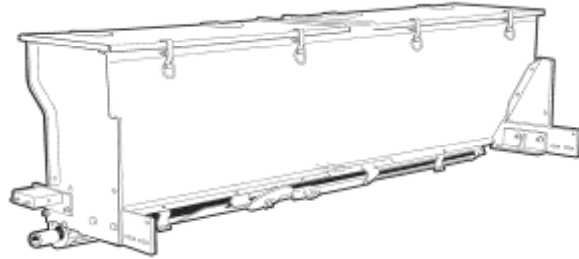

Specifications

Capacity: 1.5 cubic feet per ft. of hopper length; approx. 100 lbs./ft.
 Bottom/Slide: Diamond-shaped openings 1-1/2" long, spaced 4" apart
 Overall Height 36"
 Overall Length: 90"
 Clearance: 13" above ground; approx. 6" with spread plate

1 CHOOSE A SPREADER

Order No.	Description	Shp Wgt	List Price
1006T-TBM	6-foot Spreader. Bottom with 1-1/2 inch diamond-shaped openings spaced 4-inches apart with 18 outlets. Powder angles and mounting brackets. Approximate hopper capacity of 600 pounds (9 cu. ft.).	613 lbs.	\$ 3,269.00
1008T-TBM	8-foot Spreader. Bottom with 1-1/2 inch diamond-shaped openings spaced 4-inches apart with 24 outlets. Powder angles and mounting brackets. Approximate hopper capacity of 800 pounds (12 cu. ft.).	703 lbs.	\$ 3,528.00
1010T-TBM	10-foot Spreader. Bottom with 1-1/2 inch diamond-shaped openings spaced 4-inches apart with 30 outlets. Powder angles and mounting brackets. Approximate hopper capacity of 1,000 pounds (15 cu. ft.).	802 lbs.	\$ 3,795.00
1012-TBM	12-foot Spreader. Bottom with 1-1/2 inch diamond-shaped openings spaced 4-inches apart with 36 outlets. Powder angles and mounting brackets. Approximate hopper capacity of 1,200 pounds (18 cu. ft.).	903 lbs.	\$ 4,060.00

2 SELECT ONE: HAND LEVER, HYDRAULIC OR ELECTRIC SHUTOFF - FACTORY INSTALLED

Order No.	Description	Shp Wgt	List Price
3408236	Hand lever shutoff.	7 lbs.	\$ 77.00
3209742	*Hydraulic cylinder shutoff.	6 lbs.	\$ 322.00
0101103	Electric shutoff.		\$ 858.00

*User supplies 1/4-inch hydraulic hoses from tractor to shutoff cylinder and 1/4-inch NPT fitting

Con't. on next page

10T-TBM SERIES SPREADERS CONTINUED



6, 8, 10 and 12-Foot Spreaders for Implement Mount

For spreading fertilizer, granular limestone and seed

3 OPTIONAL MOUNTING LEG PACKAGE:

Order No.	Description	Shp Wgt	List Price
57082102	Mounting leg package of 2 for 5" x 7" implement tool bar, straight.	76 lbs.	\$ 272.00
57082104	Mounting leg package of 2 for 5" x 7" implement tool bar, offset.	69 lbs.	\$ 272.00
5708424	Mounting leg package of 1 for center leg of 10-ft., or longer span.	18 lbs.	\$ 147.00

4 OPTIONAL TOOL BAR:

Order No.	Description	Shp Wgt	List Price
5768330	6-ft. tool bar.	90 lbs.	\$ 276.00
5788330	8-ft. tool bar.	120 lbs.	\$ 313.00
57108330	10-ft. tool bar.	150 lbs.	\$ 406.00
57128330	12-ft. tool bar.	180 lbs.	\$ 453.00

5 CHOOSE A HYDRAULIC OR ELECTRIC DRIVE PACKAGE

Order No.	Description	Shp Wgt	List Price
57082100	*Hydraulic drive pkg., less hoses, 15-gallon flow.	22 lbs.	\$ 817.00
57094108	Electric drive package, 12V, 11-13 amps.	54 lbs.	\$ 1,310.00

*User supplies 1/2-inch hydraulic hoses from tractor to drive and 1/2-inch NPT fitting

6 FIELD INSTALLED OPTIONS

Order No.	Description	Shp Wgt	List Price
0185214	Calibration pan, 4-ft. for 8-ft. spreader (order 2 per unit).	6 lbs.	\$ 70.00
01105214	Calibration pan, 5-ft. for 10-ft. spreader (order 2 per unit).	8 lbs.	\$ 73.00
01125214	Calibration pan, 6-ft. for 12-ft. spreader (order 2 per unit).	11 lbs.	\$ 76.00
0108013	Clamp-on hole closure.		\$ 13.00
0108190	Deflectors, side-dressing or banding.	3 lbs.	\$ 72.00
0101103	Electric actuator shutoff.		\$ 858.00
3209742	Hydraulic cylinder only.	5 lbs.	\$ 322.00
3209742R	Hydraulic cylinder repair kit.	5 lbs.	\$ 44.00
57082105	Hydraulic hose package - connects hydraulic shutoff cylinder to hydraulic drive motor	5 lbs.	\$ 225.00
0197102	Manual holder package option for units not so equipped.		\$ 44.00
0566394-T	Powder angle package for 6-ft. "T" series, standard equipment, as an extra.	2 lbs.	\$ 82.00
0586394-T	Powder angle package for 8-ft. "T" series, standard equipment, as an extra.	2.5 lbs.	\$ 98.00
05106394-T	Powder angle package for 10-ft. "T" series, standard equipment, as an extra.	3 lbs.	\$ 106.00
05127694-T	Powder angle package for 12-ft. "T" series, standard equipment, as an extra.	3.5 lbs.	\$ 115.00
5708210	Spout holder package, centered angle spout only, order one per outlet.	1 lbs.	\$ 18.00

Con't. on next page

10T-TBM SERIES SPREADERS CONTINUED



6, 8, 10 and 12-Foot Spreaders for Implement Mount
For spreading fertilizer, granular limestone and seed

Conversion packages to T-series for discontinued spreaders are listed below. To ensure correct rate chart usage, please note that:

- Current Production Model: 10T Series has 1-1/2 inch openings spaced 4-inches apart
- 10 Series has 2-inch openings spaced 6-inches apart
- 10A Series has 1-1/2 inch openings spaced 3-3/8 inches apart
- 10S Series has 1-1/2 inch openings spaced 6-inches apart

RETROFIT KITS

Order No.	Description	Shp Wgt	List Price
0568011&12PKG	Retrofit 10T bottom, slide & rotor package, 6 ft. for discontinued 1006 &1006A models.	103 lbs.	\$ 957.00
0588011&12PKG	Retrofit 10T bottom, slide & rotor package, 8 ft. for discontinued 1008 &1008A models.	122 lbs.	\$ 1,108.00
05108011&12PKG	Retrofit 10T bottom, slide & rotor package, 10 ft. for discontinued 1010 & 1010A models.	142 lbs.	\$ 1,289.00
05128011&12PKG	Retrofit 10T bottom, slide & rotor package, 12 ft. for discontinued 1012 & 1012A models.	164 lbs.	\$ 1,468.00

LINEAR APPLICATOR

Applies Grass Seed and Granular Chemicals



Standard Equipment

- Mount on field implements for pre-plant application of granular chemicals or to sow selected small grains and grass seed
- Order in combinations to match width and folding characteristics of parent machine
- Hydraulic or optional heavy-duty electric drive
- Internal hex shaft with 5-bladed rubber rotor
- Optional 14-degree angled spouts are available

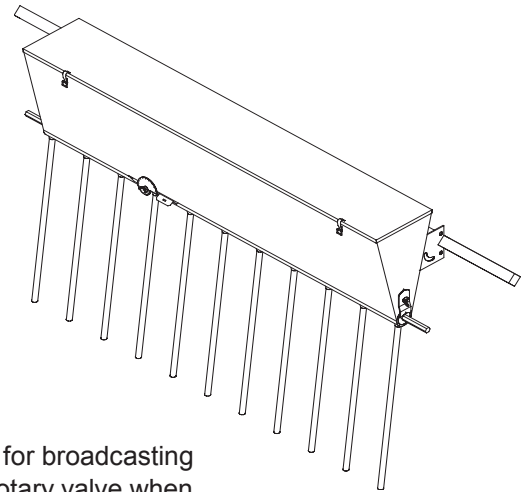

Specifications

- Rotor:** 5-bladed resilient rubber rotor on hexagonal shaft for broadcasting heavy-core granules or sowing seeds. Acts as a rotary valve when stopped
- Bearings:** Bronze sleeved bearings are porous and oil impregnated
- Mounting:** User must provide mounting brackets, posts, etc. to install hopper on parent implement

1 CHOOSE A LINEAR APPLICATOR

Order No.	Description	Shp Wgt	List Price
405L	5-ft., 2.5 cu. ft. (49.5dm ³ /m) 10-outlet hopper with stainless steel bottom/slide and mounting rail.	120 lbs.	\$ 1,335.00
409L	9-ft., 18-outlet hopper with stainless steel bottom/slide and mounting rail.	220 lbs.	\$ 2,018.00
410L	10-ft., 20-outlet hopper with stainless steel bottom/slide and mounting rail.	240 lbs.	\$ 2,205.00

2 SELECT DRIVE OPTION:

Order No.	Description	Shp Wgt	List Price
24219	*Hydraulic drive.	40 lbs.	\$ 966.00
24223	12-volt electric drive, 1/4-hp for up to 19-ft. of hopper.	34 lbs.	\$ 1,115.00

*User supplies hydraulic hoses for 1/2-inch NPT fitting

3 OPTIONAL HYDRAULIC SHUTOFF

Order No.	Description	Shp Wgt	List Price
3209742	*Hydraulic shutoff cylinder (1 required for each hopper).	6 lbs.	\$ 322.00

*User supplies 1/4-inch hydraulic hoses from tractor to shutoff cylinder and 1/4-inch NPT fitting

Con't. on next page

LINEAR APPLICATOR CON'T.

Applies Grass Seed and Granular Chemicals



4 OPTIONAL HOLE CLOSURE

Order No.	Description	Shp Wgt	List Price
2408060	Hole closure to seal off bottom outlet.		\$ 15.00

5 OPTIONAL CONNECTOR PACKAGES

Order No.	Description	Shp Wgt	List Price
24218	Connector package for second hopper.	3 lbs.	\$ 76.00
24221	Universal joint connector package, 14" to 22", hex shaft.	20 lbs.	\$ 372.00
24222	Universal joint connector package, 44" to 76", hex shaft.	28 lbs.	\$ 339.00

6 REPLACEMENT SPROCKETS

Order No.	Description	Shp Wgt	List Price
0406545-C8	60-tooth hex sprocket for electric drive.		\$ 136.00
0406545-C9	60-tooth hex sprocket for hydraulic drive.		\$ 227.00
0406545/2	Hex hub for welding to existing drive sprocket.	4 oz.	\$ 31.00

7 ROTOR BAR CONVERSION PACKAGES

Order No.	Description	Shp Wgt	List Price
14869	Rotor bar package, hex shaft, 8-ft., to convert hopper with pentagon shaft to hex shaft.	28 lbs.	\$ 412.00
141069	Rotor bar package, hex shaft, 10-ft., to convert hopper with pentagon shaft to hex shaft.	30 lbs.	\$ 491.00
141269	Rotor bar package, hex shaft, 12-ft., to convert hopper with pentagon shaft to hex shaft.	40 lbs.	\$ 578.00

MEASURING WHEELS



Standard Equipment

- Measures distances as fast as you can walk
- Direct reading models in either feet or meters

Specifications

Counter: Quick-reset digital counters read directly in feet (meters for 1.5M)

5F & 1.5M Tire: Precision-ground, rubber-tired five-spoke steel wheel

10F Wheel: Four-spoke tubular steel wheel

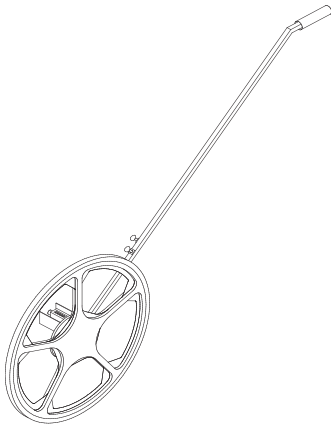

Model 1.5M

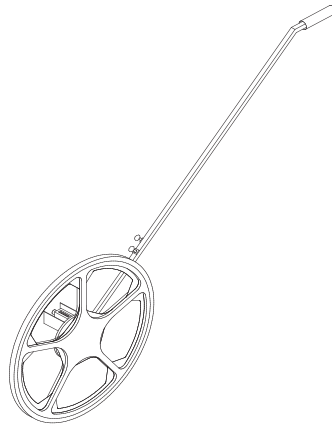

Model 5F

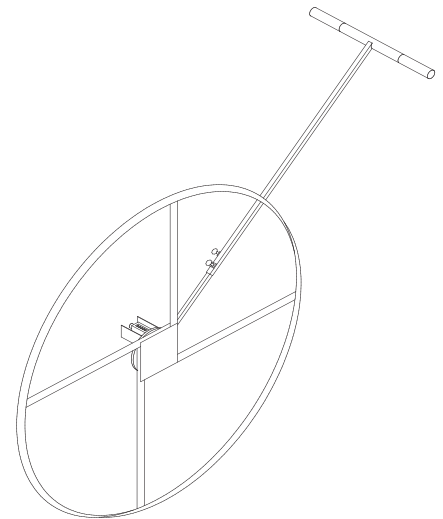

Model 10F

1 CHOOSE A MEASURING WHEEL

Order No.	Description	Shp Wgt	List Price
5F	5-ft. circumference measuring wheel. Reads in feet.	10 lbs.	\$ 250.00
10F	10-ft. circumference measuring wheel. Reads in feet.	14 lbs.	\$ 250.00
1.5M	1.5-meter circumference measuring wheel; reads in meters and decimeters.	10 lbs.	\$ 256.00

2 REPLACEMENT PARTS

Order No.	Description	Shp Wgt	List Price
M02-5F00-000	Replacement counter.	4 oz.	\$ 85.00



Limited Warranty

The Anertec & Gandy Company warrants all material and workmanship on equipment delivered to be free of defects for a period of twelve months from date of original purchase. Products used on a commercial, rental or leased basis are warranted for 90 days. Any part or parts thought to be defective within these warranty periods are to be returned through your servicing dealer or distributor to the Anertec & Gandy Company's plant. Distributor must receive authorization from Anertec & Gandy Company to return items under warranty. An authorization number will be issued and must be clearly visible on all packages returned to the factory. If found defective by Anertec & Gandy Company, replacement parts will be forwarded free of charge, prepaid. No service charge or expense on the equipment will be allowed unless such expense has been previously authorized in writing by the Anertec & Gandy Company. Serial number and model of the unit involved is required by the Anertec & Gandy Company on all warranty claims. Anertec & Gandy Company policy is to improve products whenever it is practical to do so. It reserves the right to make changes or add improvements at any time without incurring any obligation to make such changes on products sold previously. This warranty does not apply to products altered by users after the point of manufacture.

This warranty against defects in material and workmanship is in lieu of all other warranties, expressed or implied, and there are no other warranties of any kind whatsoever including, but not limited to, any implied warranty of merchantability or fitness for any particular purpose. In no event shall the company be liable for any incidental or consequential damages whether for breach of warranty, for breach or repudiation of any other term or condition hereof, or for negligence, on the basis of strict liability, or for any other reason.

This price book contains information that is correct at the time of printing; however, Anertec & Gandy Company reserves the right to change specifications, models, equipment or prices without incurring obligation. Images shown are for information purposes only, and may not necessarily represent the configurable options.

AGRAB01015

Printed in USA

© Anertec Gandy Company
Price List Effective
January 1, 2015

F.O.B.
Owatonna, MN
All Prices in US Funds